

NOTES: UNLESS OTHERWISE SPECIFIED

1. SEE DRAWING NO. CB-00391 AND PROCEDURE P-1000 FOR ASSEMBLY AND TEST INSTRUCTION. PROCEDURES AND ASSEMBLY DRAWINGS ARE FOR INTERNAL USE ONLY.
2. ALL TESTING IS PERFORMED IAW BATTERY COUNCIL INTERNATIONAL STANDARDS.
3. ALL DIMENSIONS ARE INCH [MILLIMETER].
4. M8 TERMINAL HARDWARE PROVIDED WITH BATTERY.

REVISIONS			
REV	DESCRIPTION	DATE	APPROVED
A	UPDATED FOR EU 1542 COMPLIANCE	8/16/24	PH

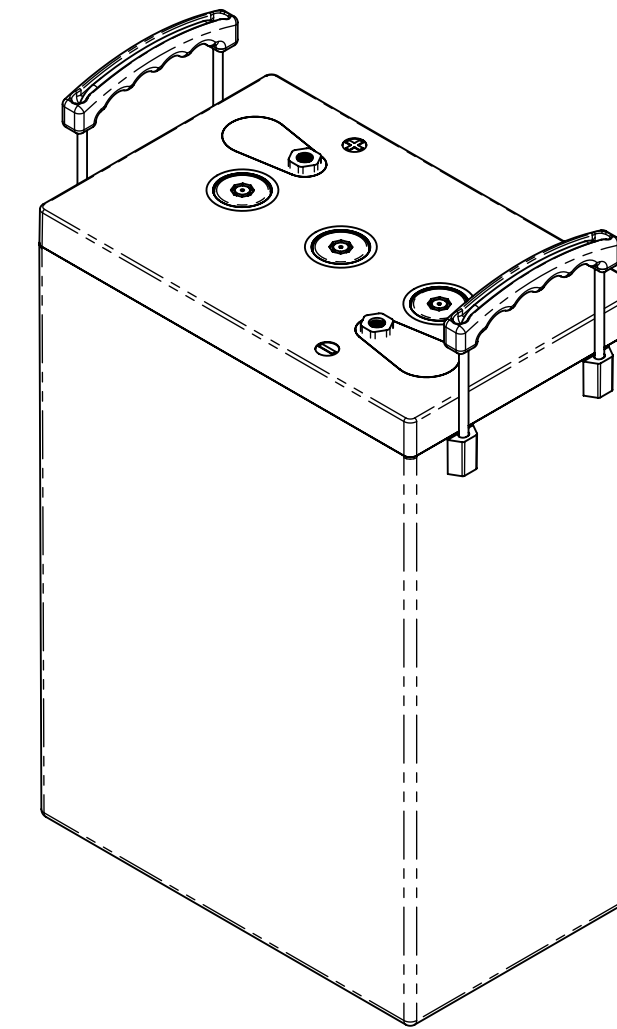
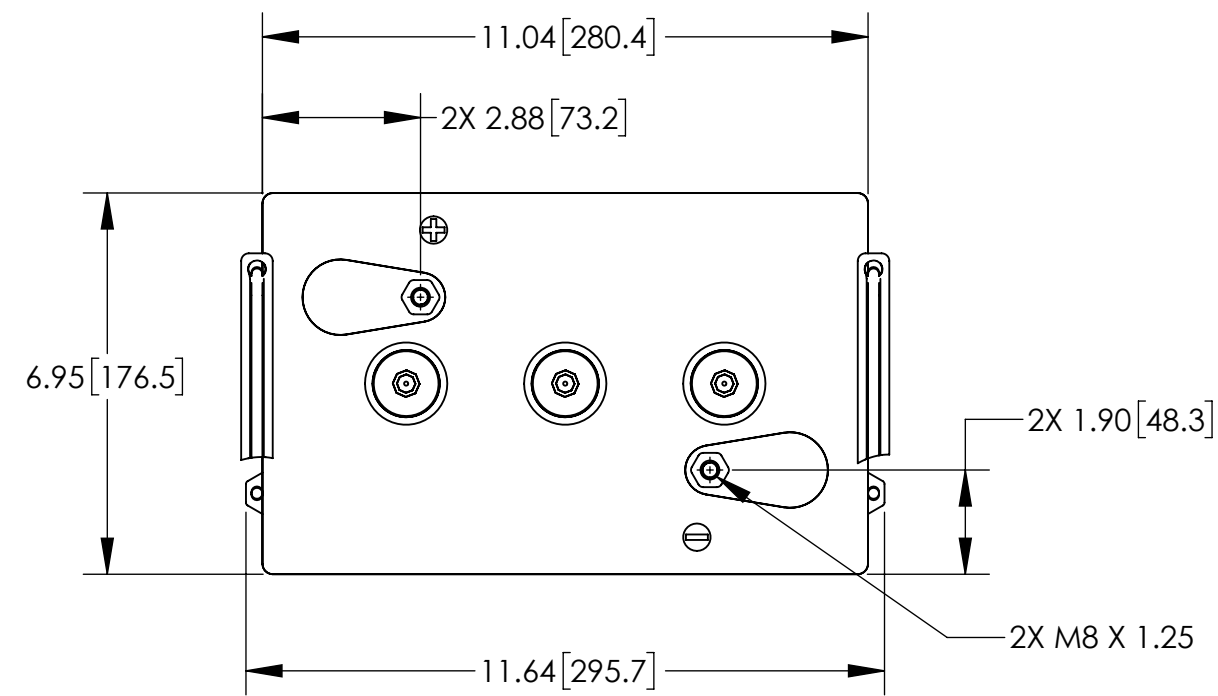

REFERENCE VIEW

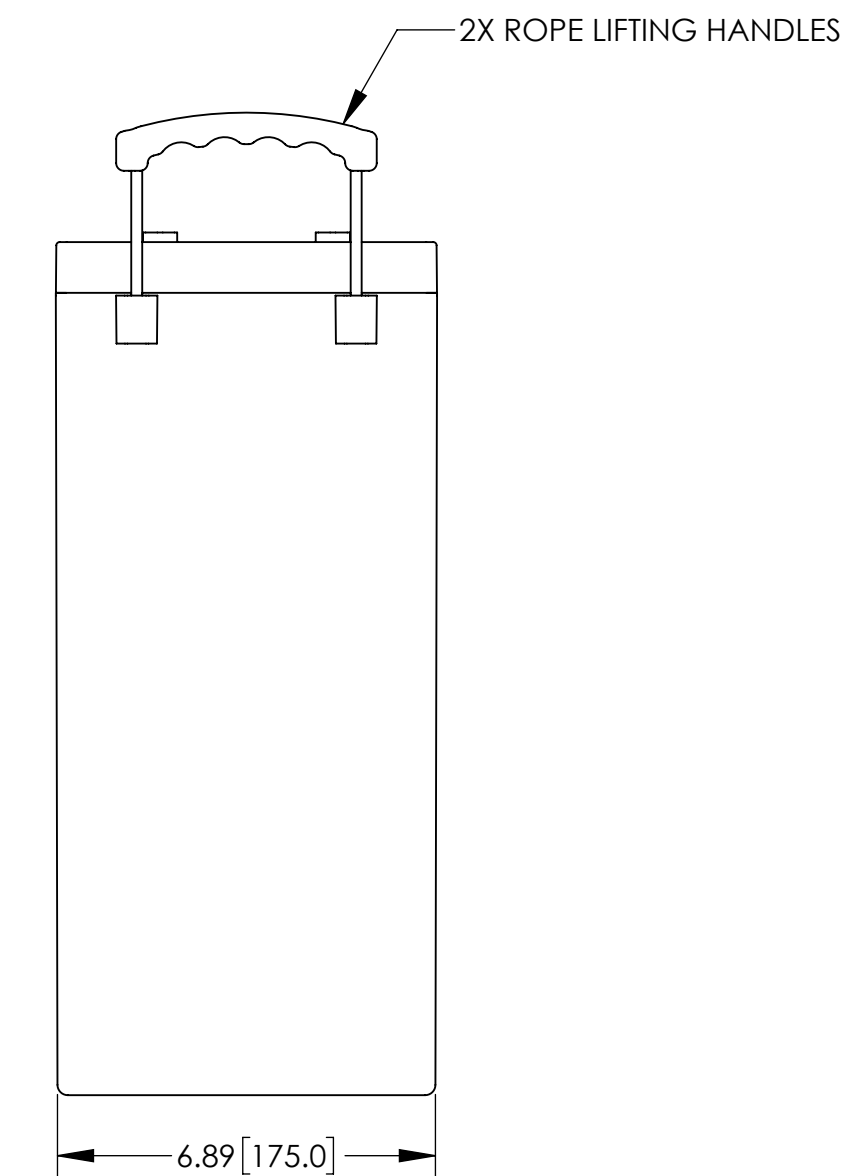
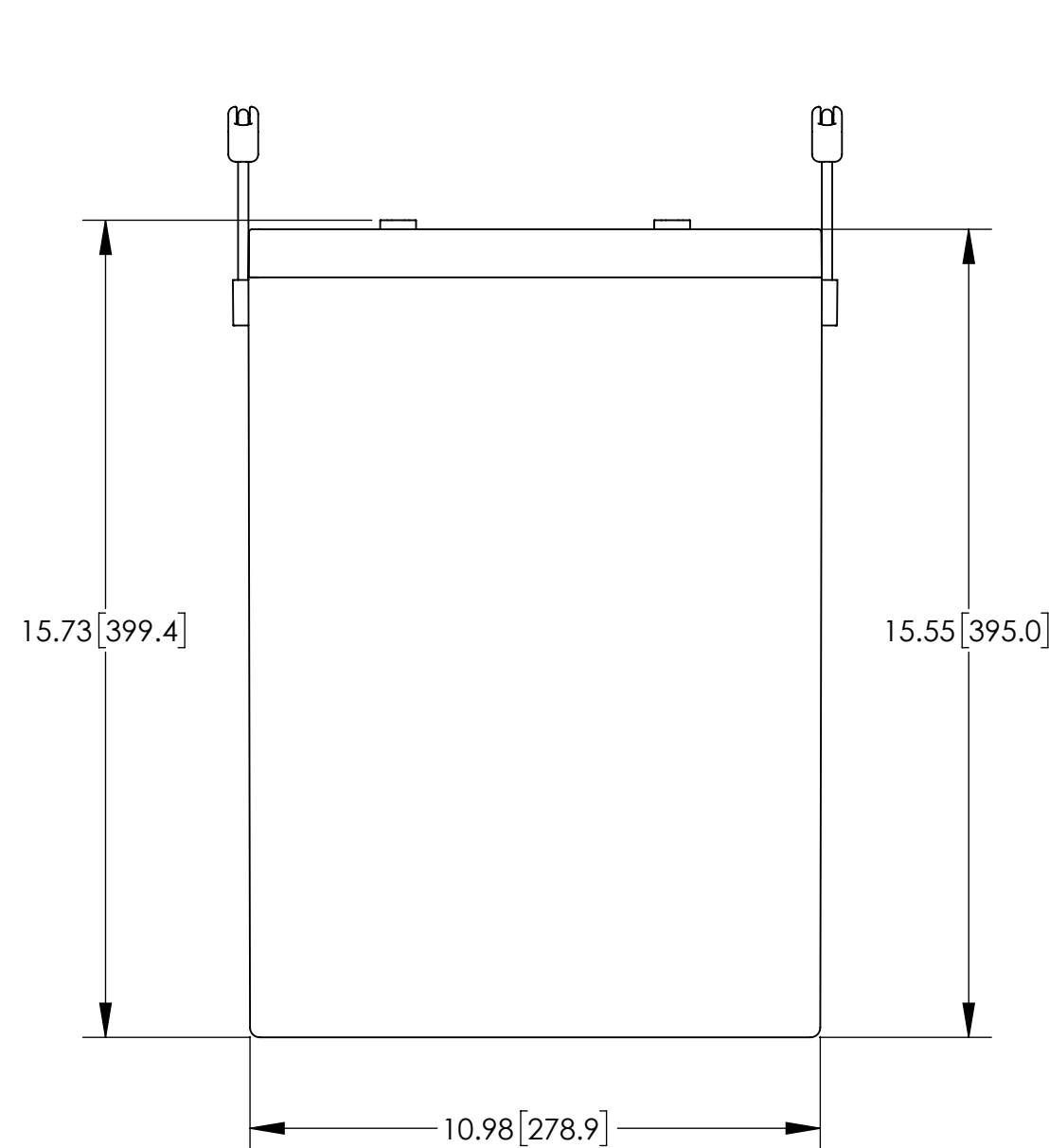

ENVELOPE DRAWING

PART NUMBER	PVX-4050HT
NOMINAL WEIGHT	120 LBS [54.4 KG]
NOMINAL VOLTAGE	6 VOLTS
RATED CAPACITY @ 24 HOUR RATE TO 1.75VPC @ 77°F (25°C)	405 AH
RATED ENERGY @ 24 HOUR RATE TO 1.75VPC @ 77°F (25°C)	2430 WH
NOMINAL INTERNAL RESISTANCE @ 77°F (25°C)	0.72 MILLIOHMS
MAXIMUM POWER @ 77°F (25°C)	12.5 KW
CAPACITY FADE	TYPICALLY 50% OR 80% AT EOL (USER DEFINED)
POWER FADE	TYPICALLY 50% OR 80% AT EOL (USER DEFINED)
ENERGY ROUND TRIP EFFICIENCY	80%

UNLESS OTHERWISE SPECIFIED DIMENSIONS ARE IN INCHES TOLERANCES ARE:		CONTRACT NO.		CONCORDE BATTERY CORPORATION 2009 SAN BERNARDINO RD, W. COVINA, CA 91790	
FRACTIONS	DECIMALS	ANGLES	APPROVALS	DATE	TITLE
±1/32	.XX ± .12 .XXX ± .060	± 1°	DRAWN N. SANCHEZ	6/29/09	BATTERY, 6 VOLT, PVX-4050HT
TREATMENT	NONE	CHECKED AMIII	APPROVED JBT	7/16/09 7/17/09	SIZE C
FINISH	NONE	ISSUED DH	8/20/24	CAGE CODE 63017	DWG NO. PVX-4050HT
SIMILAR TO	CALC WT	SCALE 1:3.5	SHEET 1	OF 1	REV A