

NOTES: UNLESS OTHERWISE SPECIFIED

1. SEE DRAWING NO. CB-00391 AND PROCEDURE P-1000 FOR ASSEMBLY AND TEST INSTRUCTION. PROCEDURES AND ASSEMBLY DRAWINGS ARE FOR INTERNAL USE ONLY.
2. ALL TESTING IS PERFORMED IAW BATTERY COUNCIL INTERNATIONAL STANDARDS.
3. ALL DIMENSIONS ARE INCH [MILLIMETER].
4. M8 TERMINAL HARDWARE PROVIDED WITH BATTERY.

REVISIONS			
REV	DESCRIPTION	DATE	APPROVED
A	UPDATED FOR EU 1542 COMPLIANCE	8/16/24	PH

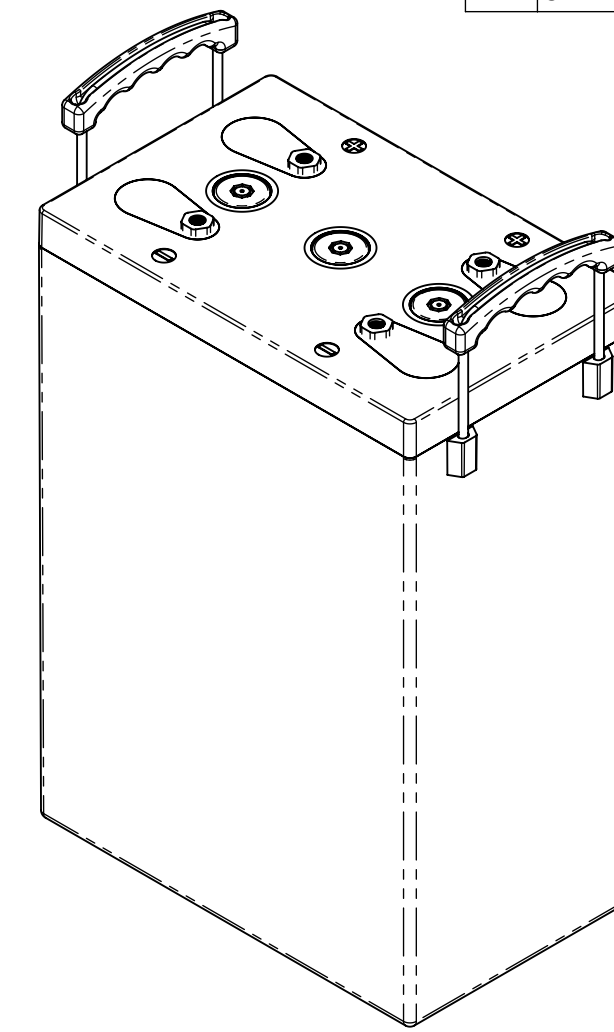
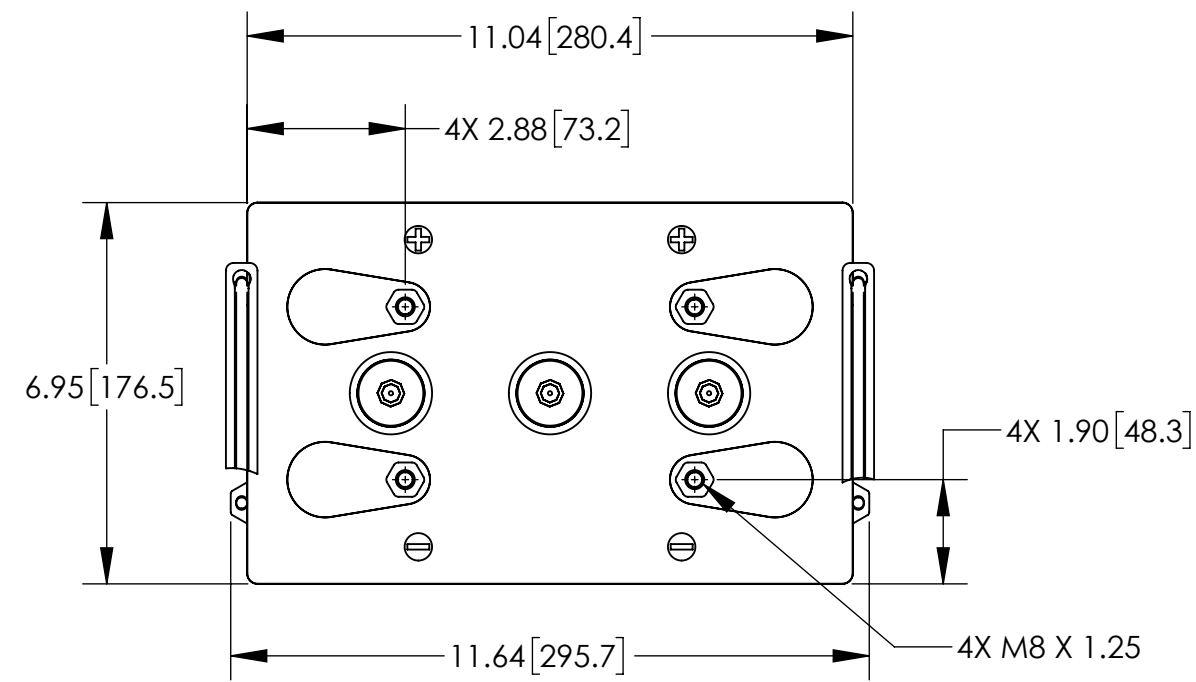

REFERENCE VIEW

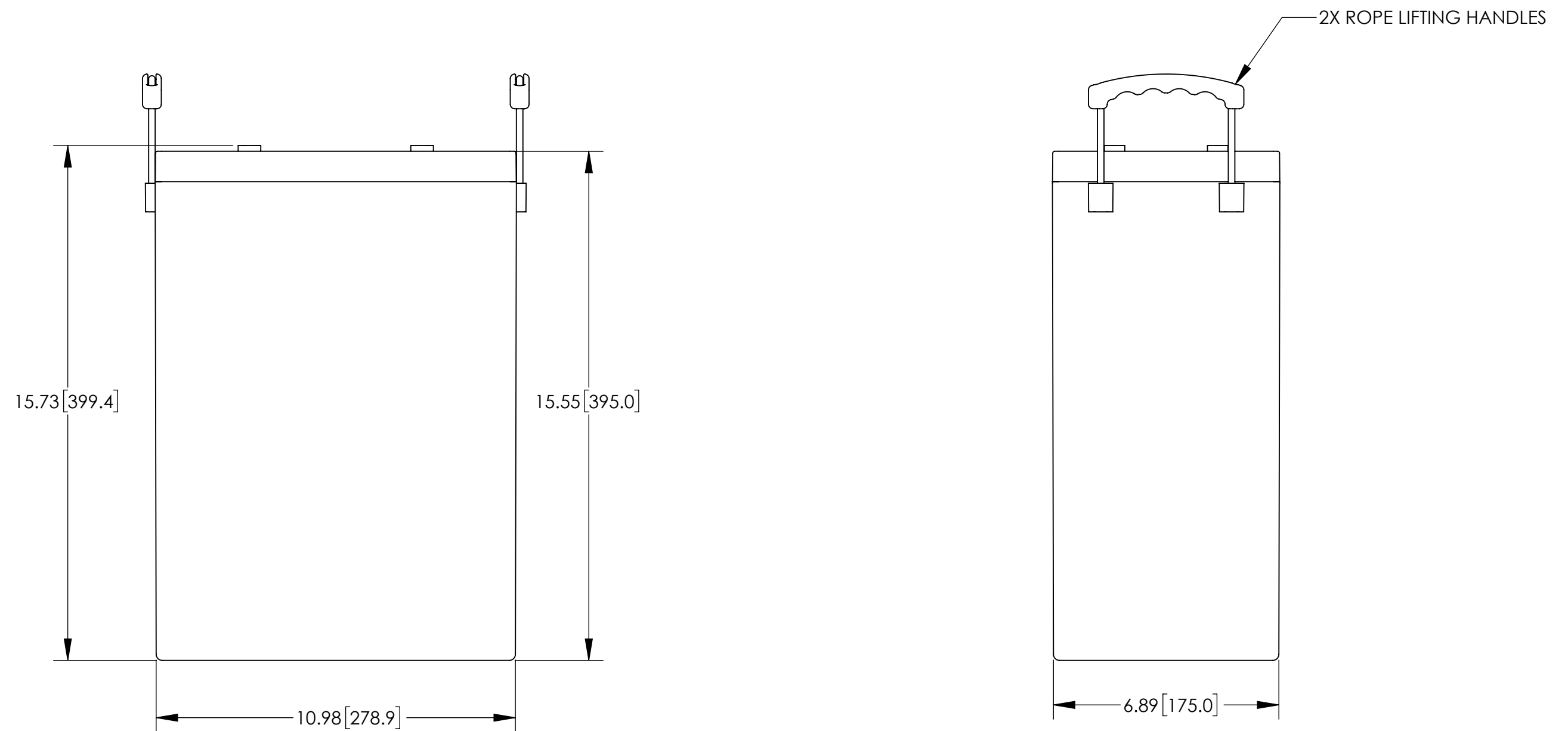

ENVELOPE DRAWING

PART NUMBER	PVX-12150HT
NOMINAL WEIGHT	124 LBS [56.2 KG]
NOMINAL VOLTAGE	2 VOLTS
RATED CAPACITY @ 24 HOUR RATE TO 1.75VPC @ 77°F (25°C)	1215 AH
RATED ENERGY @ 24 HOUR RATE TO 1.75VPC @ 77°F (25°C)	2430 WH
NOMINAL INTERNAL RESISTANCE @ 77°F (25°C)	0.24 MILLIOHMS
MAXIMUM POWER @ 77°F (25°C)	4.2 KW
CAPACITY FADE	TYPICALLY 50% OR 80% AT EOL (USER DEFINED)
POWER FADE	TYPICALLY 50% OR 80% AT EOL (USER DEFINED)
ENERGY ROUND TRIP EFFICIENCY	80%

UNLESS OTHERWISE SPECIFIED DIMENSIONS ARE IN INCHES TOLERANCES ARE:		CONTRACT NO.		CONCORDE BATTERY CORPORATION 2009 SAN BERNARDINO RD, W. COVINA, CA 91790			
FRACTIONS	DECIMALS	ANGLES	APPROVALS	DATE	TITLE		
±1/32	.XX ± .12 .XXX ± .060	± 1°	DRAWN	N. SANCHEZ	6/29/09	BATTERY, 2 VOLT, PVX-12150HT	
TREATMENT	NONE	CHECKED	AMIII	7/16/09	SIZE	CAGE CODE	DWG NO.
FINISH	NONE	APPROVED	JBT	7/17/09	C	63017	PVX-12150HT
SIMILAR TO	CALC WT	ISSUED	DH	8/20/24	SCALE	1:3.5	SHEET 1 OF 1