

NOTES: UNLESS OTHERWISE SPECIFIED

1. SEE DRAWING NO. CB-00281 AND PROCEDURE P-1000 FOR ASSEMBLY AND TEST INSTRUCTION. PROCEDURES AND ASSEMBLY DRAWING ARE FOR INTERNAL USE ONLY.
2. ALL TESTING IS PERFORMED IAW BATTERY COUNCIL INTERNATIONAL STANDARDS.
3. ALL DIMENSIONS ARE IN INCHES [MM]
4. TERMINAL HARDWARE KIT PROVIDED, PART NUMBER 6923

REVISIONS			
REV	DESCRIPTION	DATE	APPROVED
A	CHANGED HANDLE DIRECTION	2/26/07	JBT
B	CHANGED COVER & HANDLE, NOM. WT. 93 lbs WAS 85 lbs	11/6/07	JBT

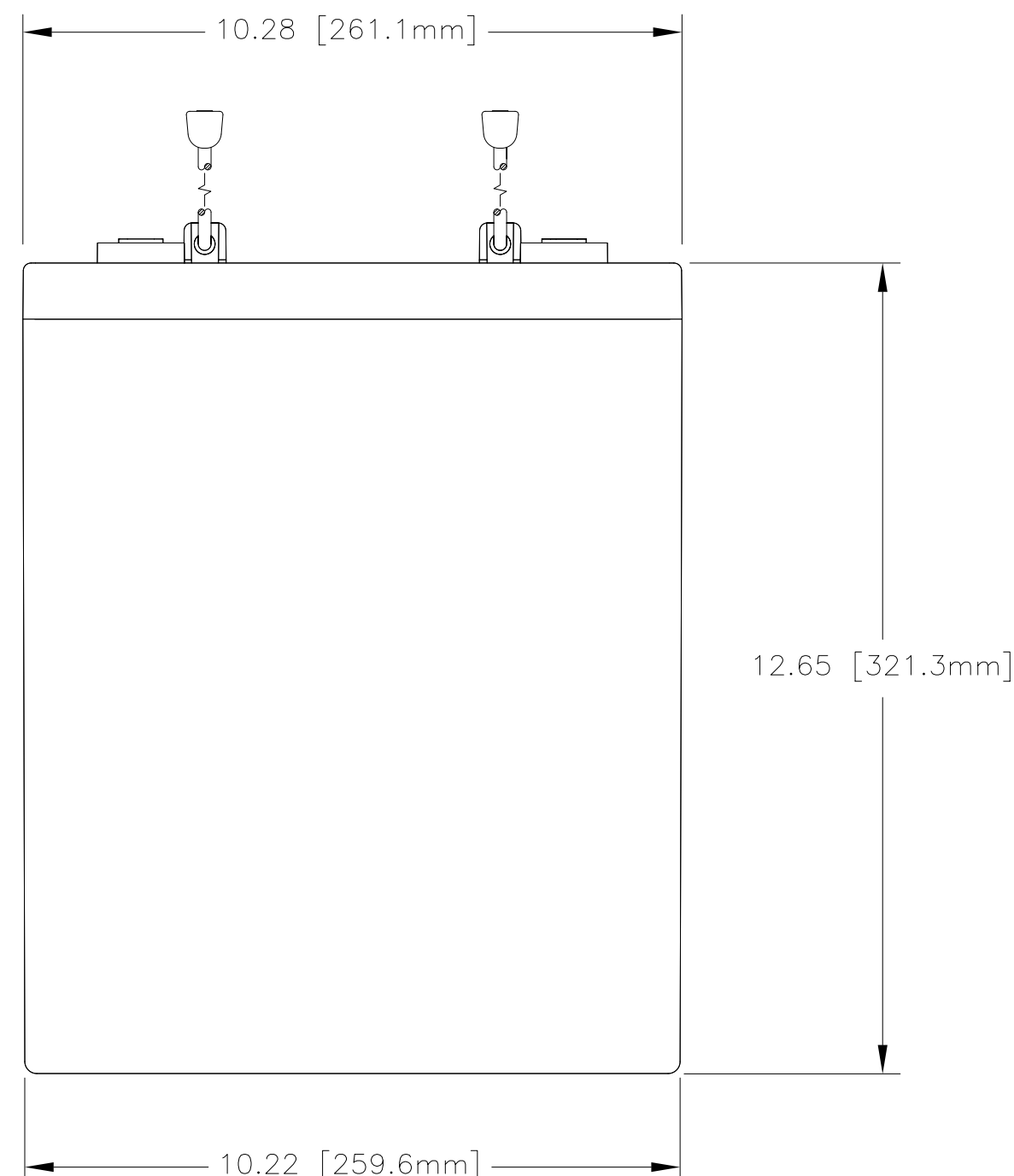
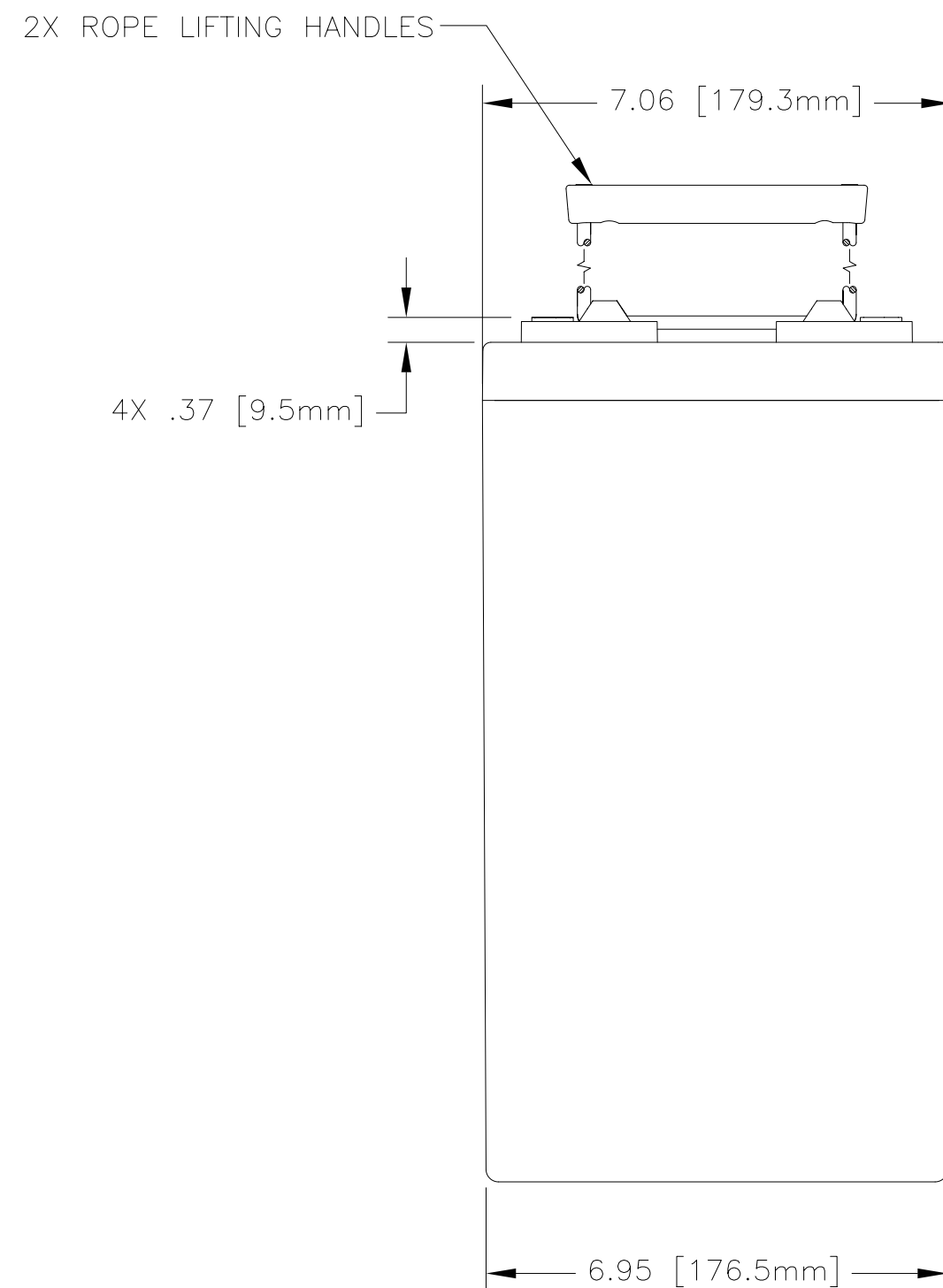
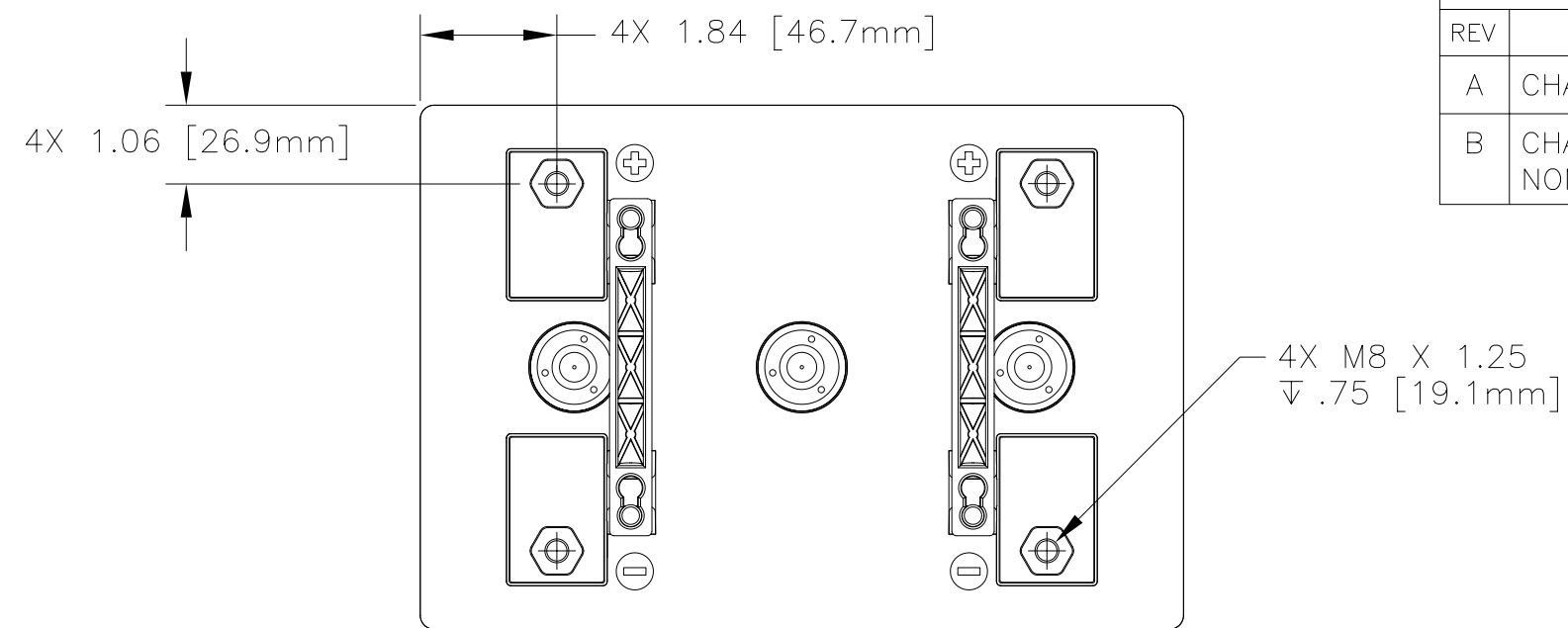

CAPACITY RATINGS	
PART NUMBER	AGM-2900T
NOMINAL WEIGHT	93 LBS [42.2 KG]
AMPERE HOUR CAPACITY @ 20 HOUR 1.75 VOLTS/CELL @ 77°F (25° C)	900 AH
MINUTES OF DISCHARGE @ 25 AMPS 1.75 VOLTS/CELL @ 77°F (25° C)	692 MIN

ENVELOPE DRAWING

QTY REQD	CAGE CODE	PART OR IDENTIFYING NO.	NOMENCLATURE OR DESCRIPTION	MATERIAL SPECIFICATION	ITEM NO.
PARTS LIST					
UNLESS OTHERWISE SPECIFIED DIMENSIONS ARE IN INCHES TOLERANCES ARE: FRACTIONS DECIMALS ANGLES ± 1/32 .XX ± .12 ± 1° .XXX ± .060			CONTRACT NO.		
TREATMENT NONE			APPROVALS	DATE	CONCORDE BATTERY CORPORATION 2009 SAN BERNARDINO RD, W. COVINA, CA 91790 TITLE BATTERY, 2 VOLT, AGM-2900T
FINISH NONE			DRAWN D. AYALA	12/15/06	
SIMILAR TO N/A			CHECKED AMIII	1/9/07	
			APPROVED JBT	1/10/07	
SCALE 1=2.5		ISSUED NS	11/29/07	SIZE C	CAGE CODE 63017 DWG NO. AGM-2900T REV B
				SHEET 1 OF 1	