

NOTES: UNLESS OTHERWISE SPECIFIED

1. SEE DRAWING NO. CB-00281 AND PROCEDURE P-1000 FOR ASSEMBLY AND TEST INSTRUCTION. PROCEDURES AND ASSEMBLY DRAWINGS ARE FOR INTERNAL USE ONLY.
2. ALL TESTING IS PERFORMED IAW BATTERY COUNCIL INTERNATIONAL STANDARDS.
3. DIMENSIONS ARE INCH [MILLIMETER].
4. TERMINAL HARDWARE KIT PROVIDED, PART NUMBER 6923 (2 REQD).

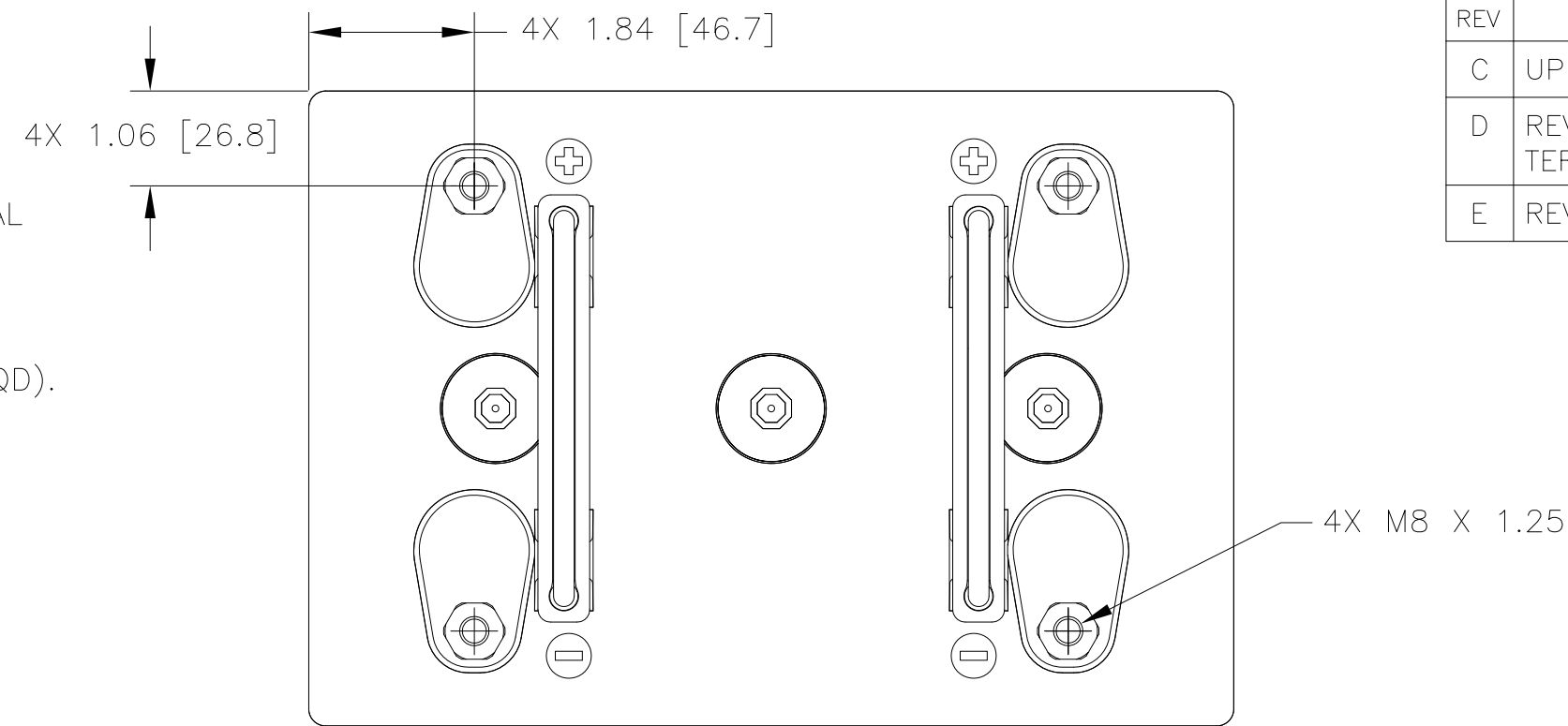

REVISIONS			
REV	DESCRIPTION	DATE	APPROVED
C	UPDATED RATINGS	1/30/08	JBT
D	REVISED TERMINAL DAMS, TERMINAL HEIGHT & HANDLES	9/16/09	JBT
E	REVISED TERMINAL HEIGHT	6/12/20	PH

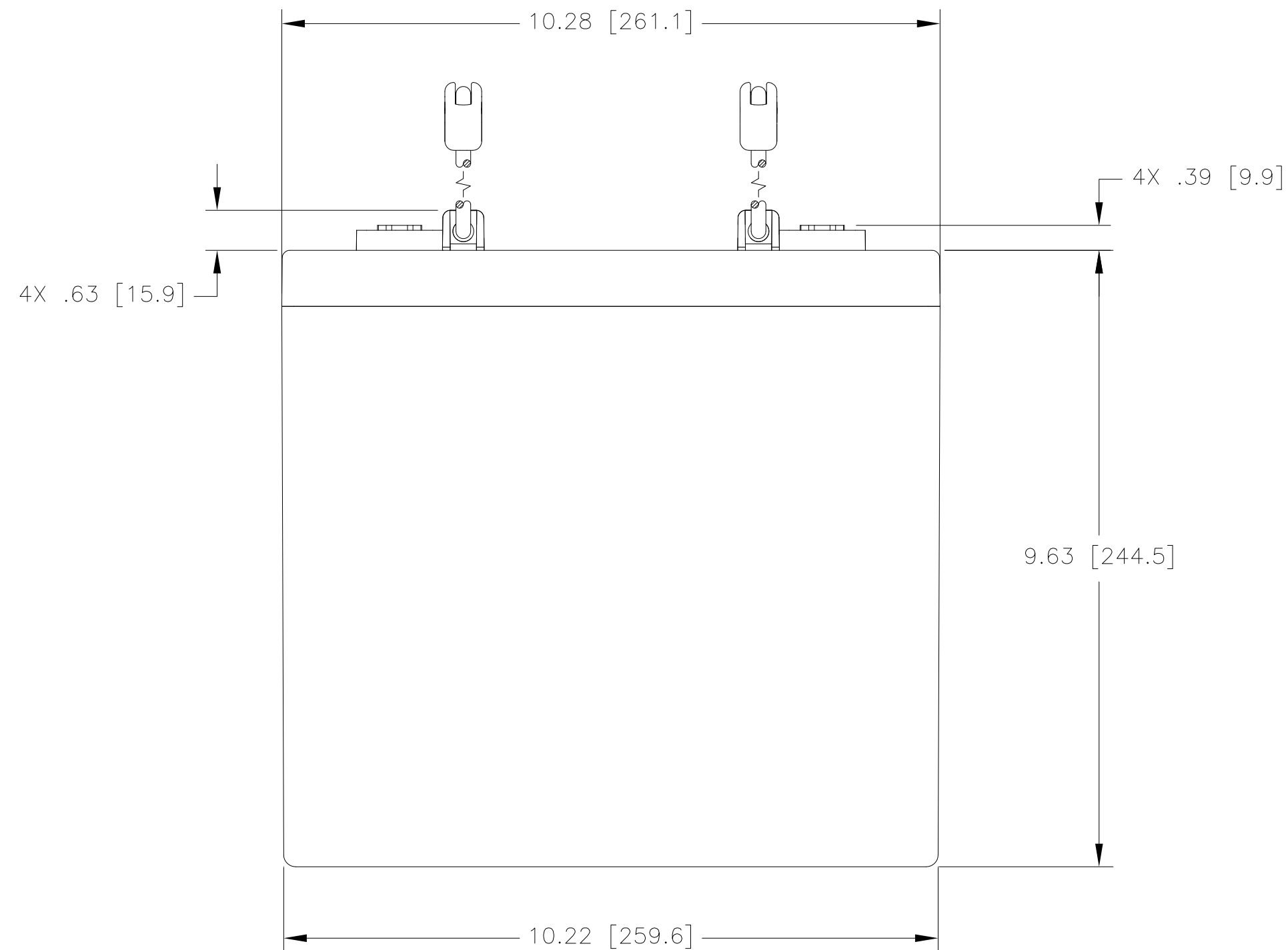
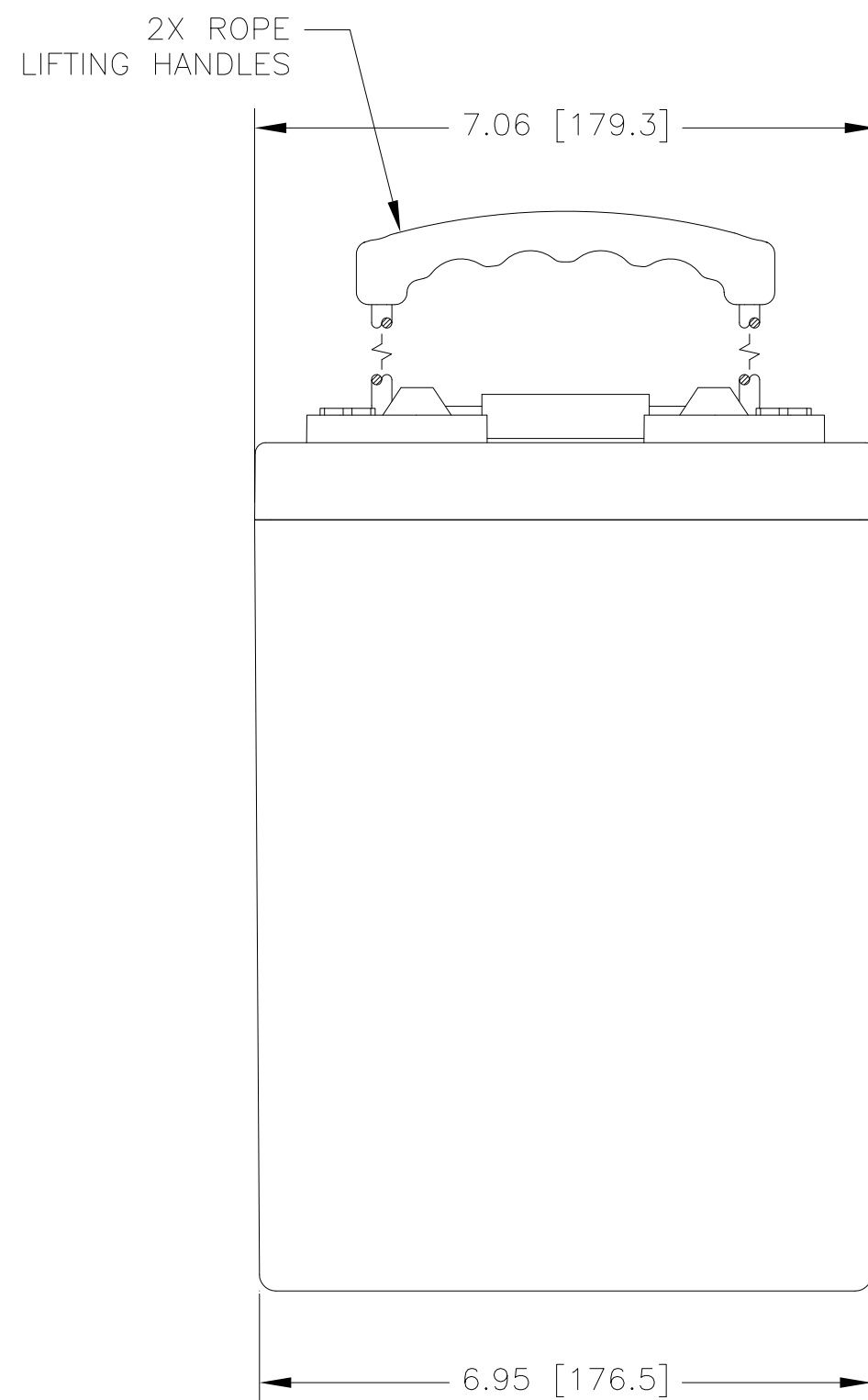

CAPACITY RATINGS	
PART NUMBER	AGM-2660T
NOMINAL WEIGHT	69 LBS [31.3 KG]
AMPERE HOUR CAPACITY @ 20 HOUR 1.75 VOLTS/CELL @ 77°F (25° C)	660 AH
MINUTES OF DISCHARGE @ 25 AMPS 1.75 VOLTS/CELL @ 77°F (25° C)	1476 MIN

ENVELOPE DRAWING

QTY REQD	CAGE CODE	PART OR IDENTIFYING NO.	NOMENCLATURE OR DESCRIPTION	MATERIAL SPECIFICATION	ITEM NO.
PARTS LIST					
UNLESS OTHERWISE SPECIFIED DIMENSIONS ARE IN INCHES TOLERANCES ARE: FRACTIONS DECIMALS ANGLES ± 1/32 .XX ± .12 ± 1' .XXX ± .060			CONCORDE BATTERY CORPORATION 2009 SAN BERNARDINO RD, W. COVINA, CA 91790		
TREATMENT NONE		APPROVALS		DATE	
FINISH NONE		DRAWN D. AYALA		12/15/06	
SIMILAR TO		CHECKED AMIII		1/9/07	
ACT WT		APPROVED JBT		1/10/07	
CALC WT		ISSUED DH		6/15/20	
TITLE BATTERY, 2 VOLT, AGM-2660T			SIZE C	CAGE CODE 63017	DWG NO. AGM-2660T
SCALE 1/2			REV E	SHEET 1 OF 1	