

NOTES: UNLESS OTHERWISE SPECIFIED

1. SEE DRAWING NO. CB-00290 AND PROCEDURE P-1000 FOR ASSEMBLY AND TEST INSTRUCTION. PROCEDURES AND ASSEMBLY DRAWINGS ARE FOR INTERNAL USE ONLY.
2. ALL TESTING IS PERFORMED IAW BATTERY COUNCIL INTERNATIONAL STANDARDS.
3. DIMENSIONS ARE INCH [MILLIMETER].
4. TERMINAL HARDWARE KIT PROVIDED, PART NUMBER 6923.

REVISIONS			
REV	DESCRIPTION	DATE	APPROVED
A	STANDARDIZED ENVELOPE, ADDED NOTE 4	7/17/20	PH

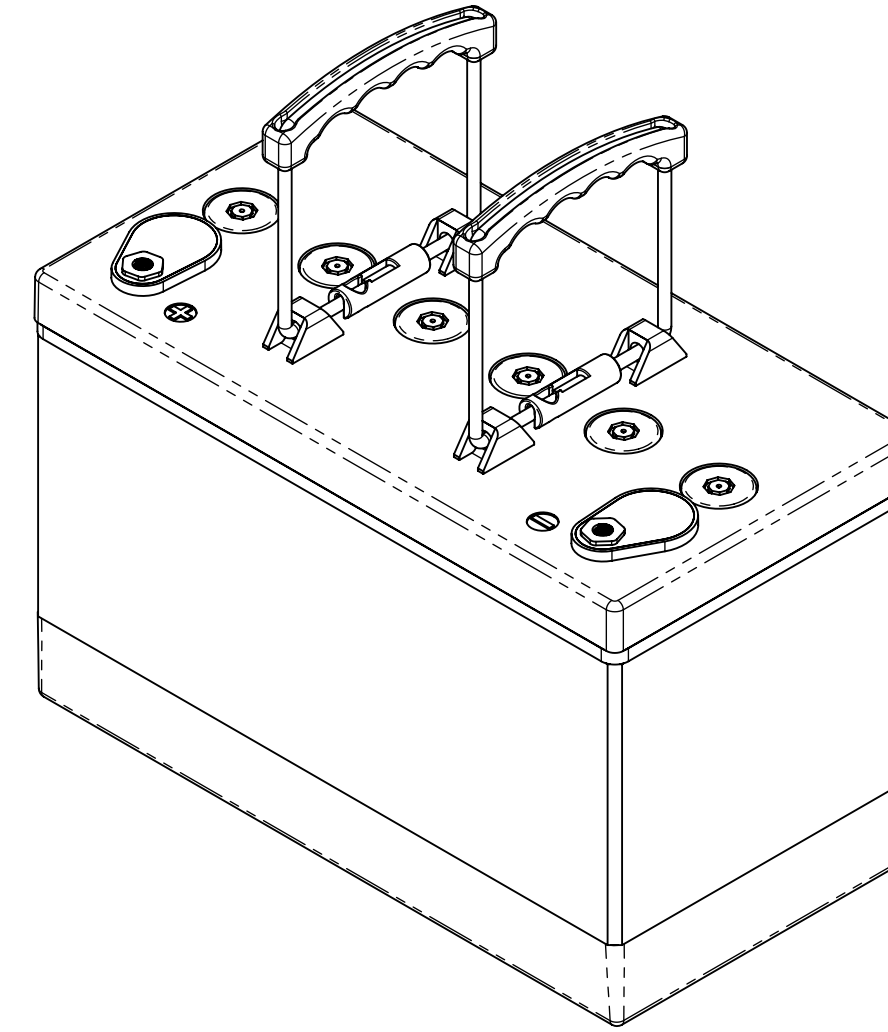

ISOMETRIC VIEW

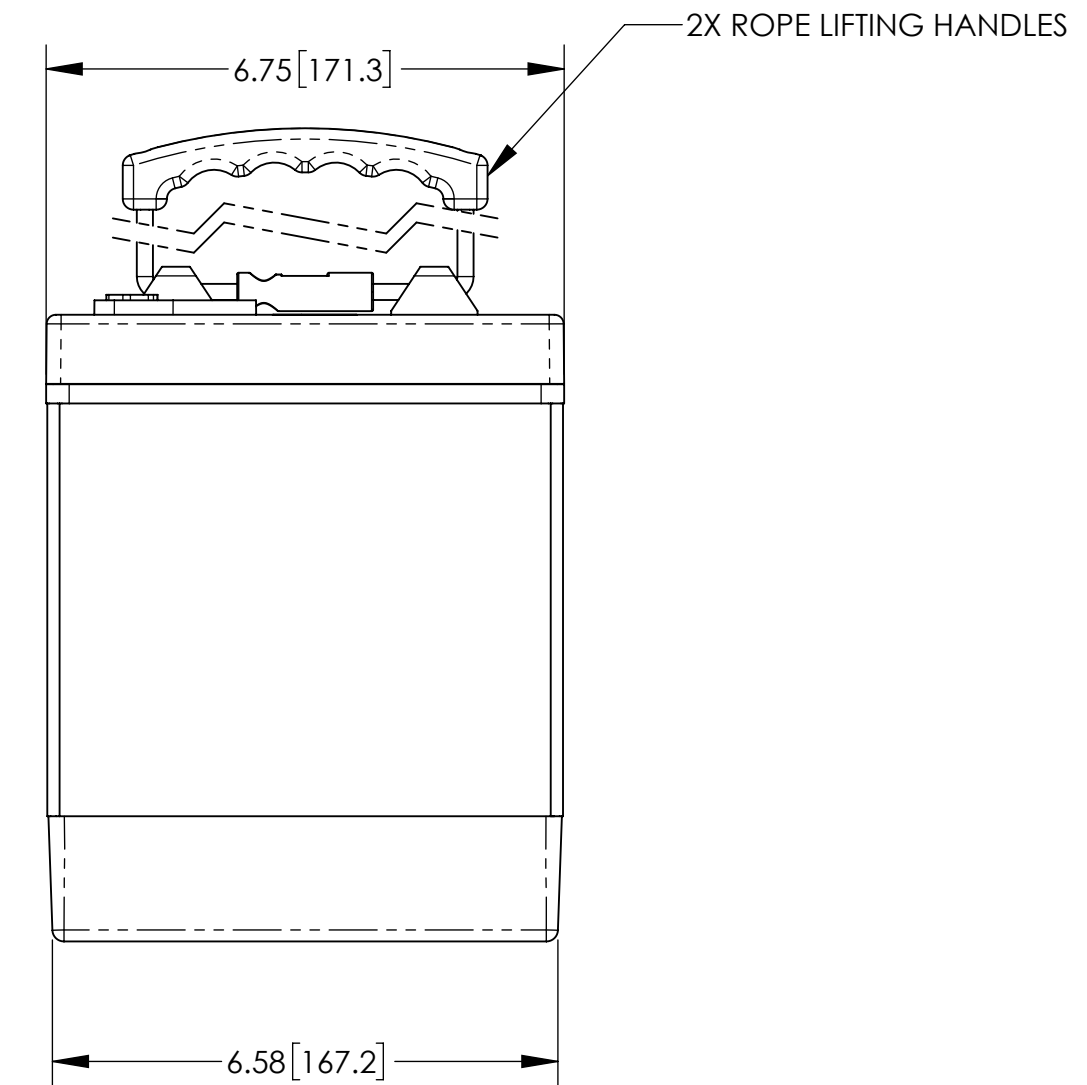
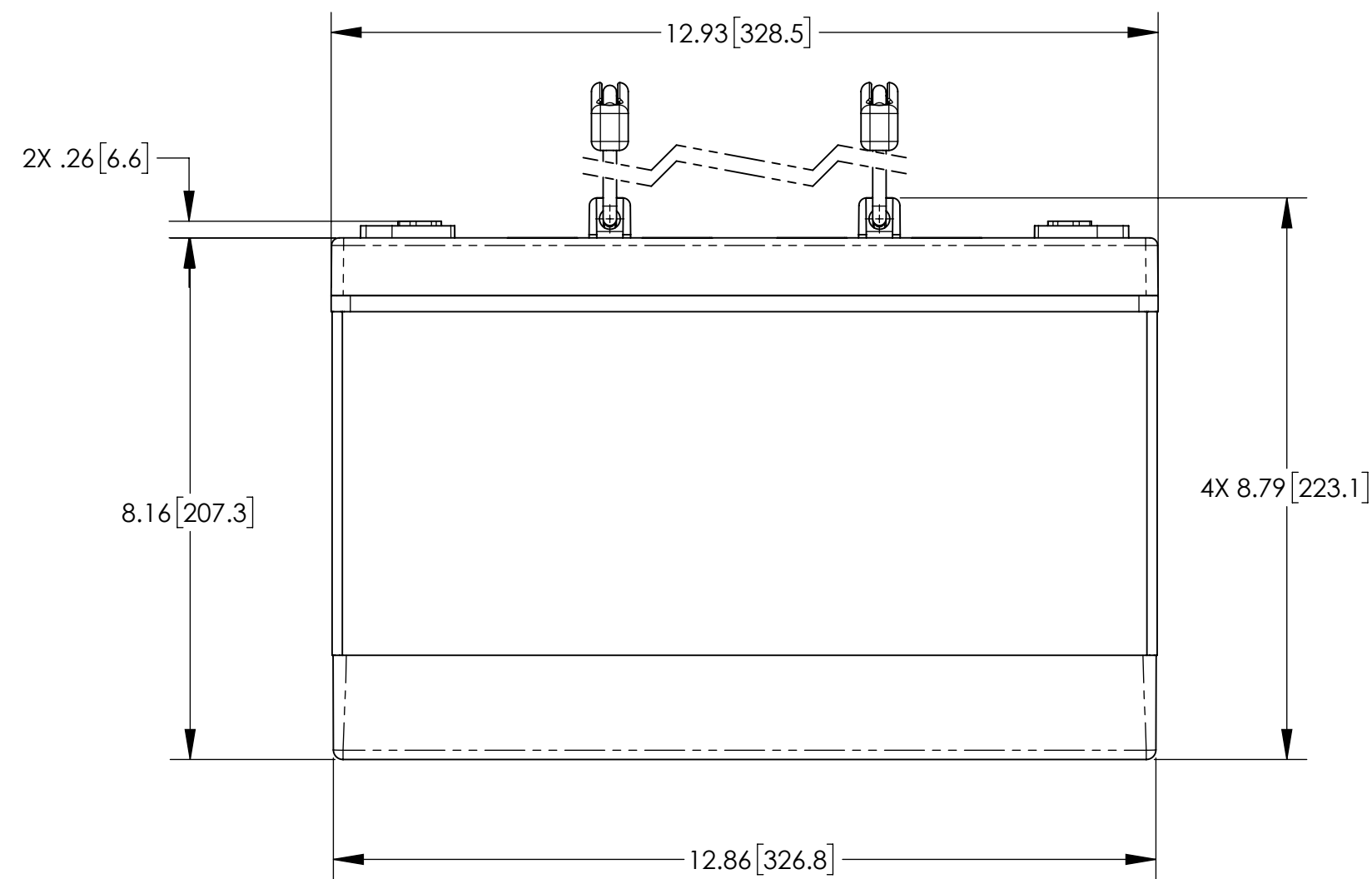
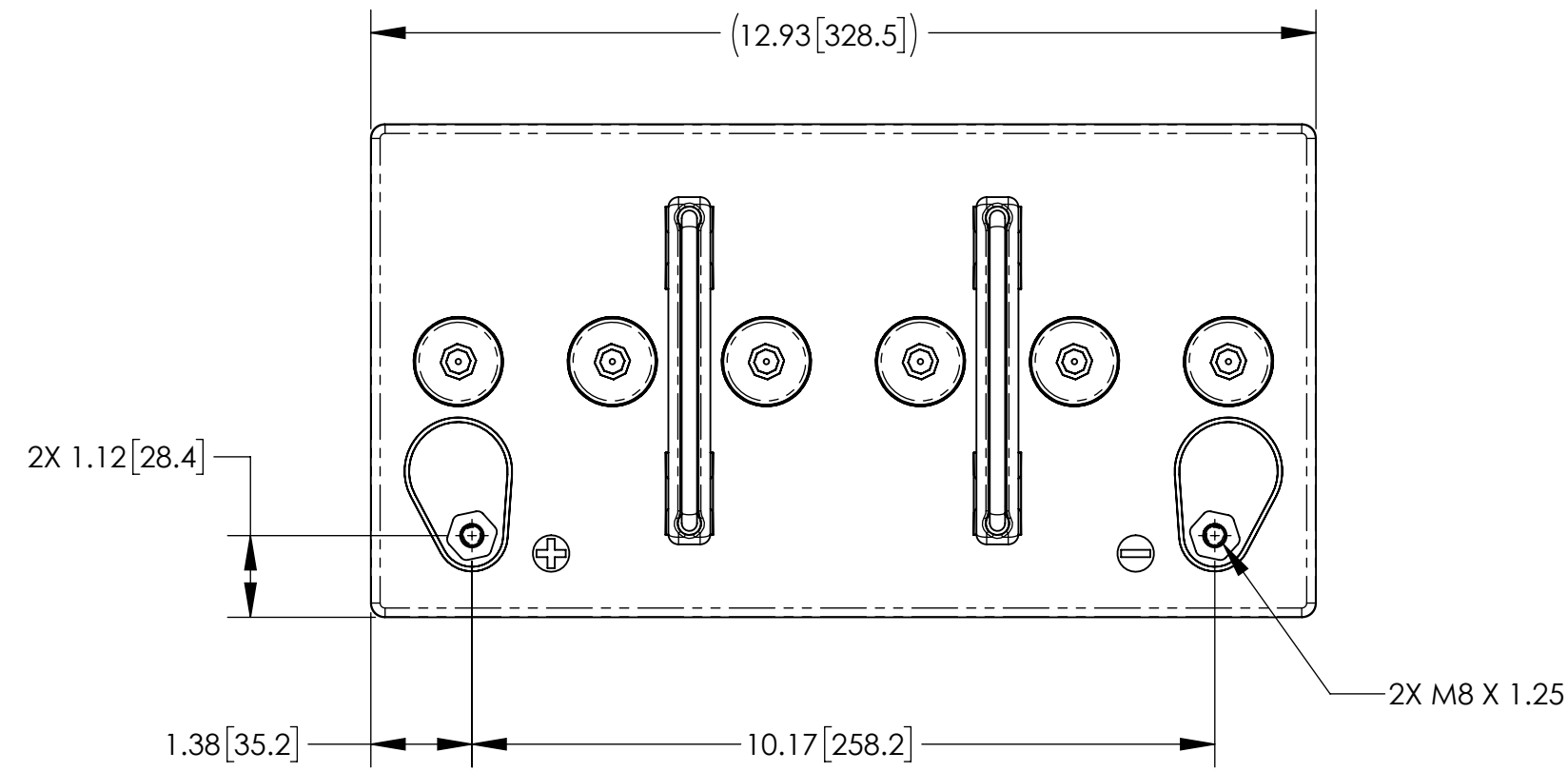

ENVELOPE DRAWING

CAPACITY RATINGS	
PART NUMBER	AGM-1285T
NOMINAL WEIGHT	62 LBS [28.2 KG]
AMPERE HOUR CAPACITY @ 20 HOUR 1.75 VOLTS/CELL @ 77°F (25°C)	85 AH
MINUTES OF DISCHARGE @ 25 AMPS 1.75 VOLTS/CELL @ 77°F (25°C)	158 MIN

UNLESS OTHERWISE SPECIFIED DIMENSIONS ARE IN INCHES TOLERANCES ARE: FRACTIONS DECIMALS ANGLES ±1/32 .XX ±.12 ±1° .XXX ±.060	CONTRACT NO.		CONCORDE BATTERY CORPORATION 2009 SAN BERNARDINO RD, W. COVINA, CA 91790		
	APPROVALS	DATE	TITLE		
TREATMENT	CHECKED	NS	5/29/19	BATTERY, 12 VOLT, AGM-1285T	
FINISH	APPROVED	PH	5/29/19	SIZE C	CAGE CODE 63017
SIMILAR TO	ISSUED	DH	7/20/20	DWG NO.	AGM-1285T
				SCALE	1:2.5
				SHEET	1 OF 1