

NOTES: UNLESS OTHERWISE SPECIFIED

1. SEE DRAWING NO. CB-00278 AND PROCEDURE P-1000 FOR ASSEMBLY AND TEST INSTRUCTION. PROCEDURES AND ASSEMBLY DRAWINGS ARE FOR INTERNAL USE ONLY.
2. ALL TESTING IS PERFORMED IAW BATTERY COUNCIL INTERNATIONAL STANDARDS.
3. DIMENSIONS ARE INCH [MILLIMETER].
4. TERMINAL HARDWARE KIT PROVIDED, PART NUMBER 6923.

REVISIONS			
REV	DESCRIPTION	DATE	APPROVED
A	REVISED CAPACITY TABLE	3/15/00	JBT
B	METRICIZED INSERT	12/23/00	JBT
C	REMOVED SIDE HOLD-DOWNS	7/23/01	JBT
D	REDESIGNED COVER	6/26/18	PH
E	STANDARDIZED ENVELOPE, ADDED NOTE 4	7/17/20	PH
F	REVISED CONTAINER	11/10/21	PH

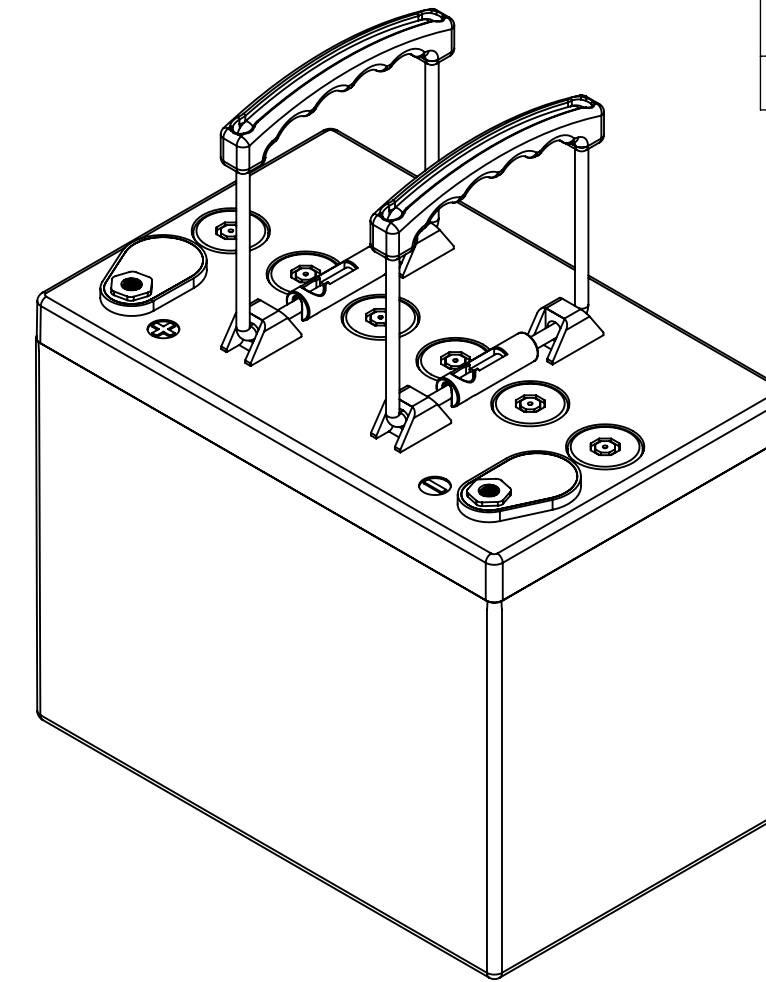
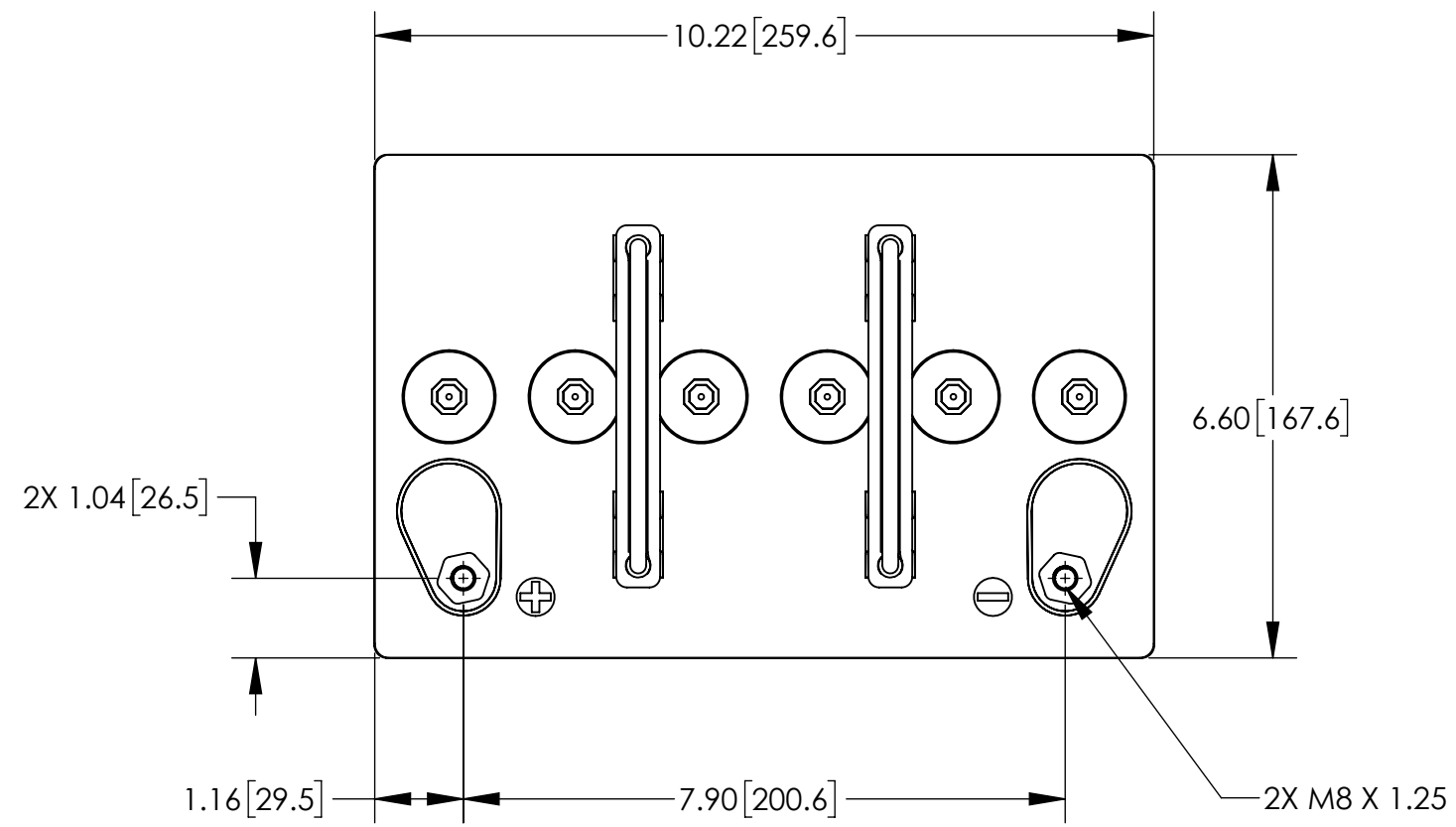

ISOMETRIC VIEW

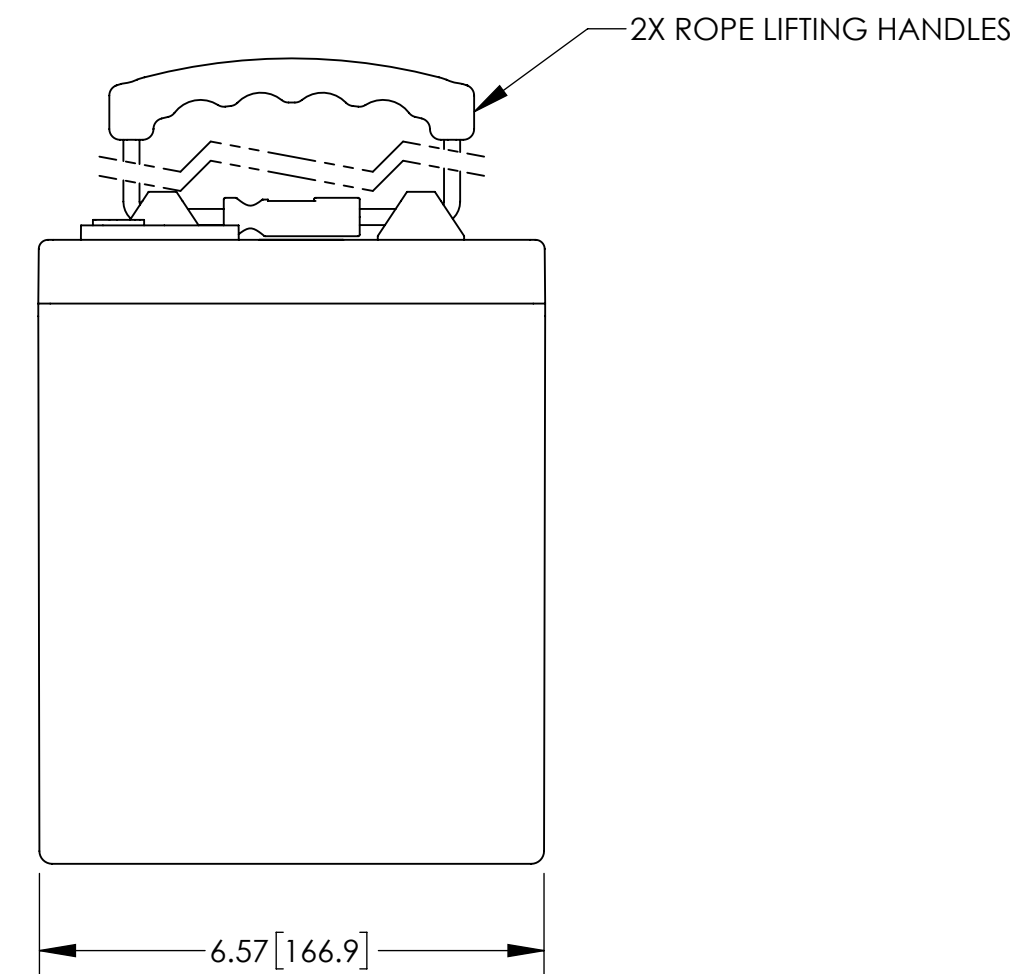
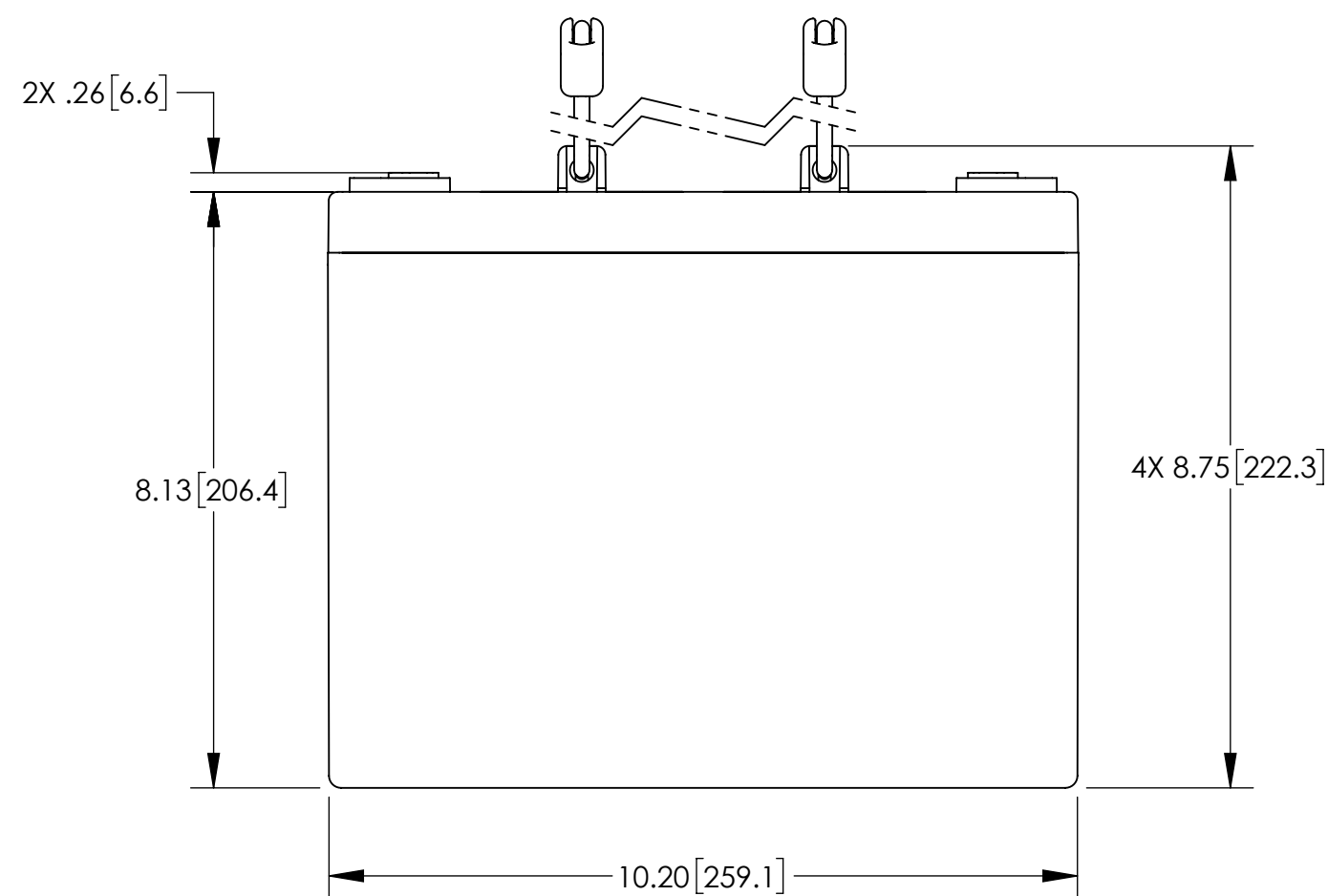

CAPACITY RATINGS		
PART NUMBER	AGM-1265T	AGM-1280T
NOMINAL WEIGHT	50 LBS [22.7 KG]	56 LBS [25.4 KG]
AMPERE HOUR CAPACITY @ 20 HOUR 1.75 VOLTS/CELL @ 77 °F (25°C)	65 AH	80 AH
MINUTES OF DISCHARGE @ 25 AMPS 1.75 VOLTS/CELL @ 77 °F (25°C)	121 MIN	149 MIN

ENVELOPE DRAWING

<small>UNLESS OTHERWISE SPECIFIED DIMENSIONS ARE IN INCHES TOLERANCES ARE:</small> FRACTIONS DECIMALS ANGLES $\pm 1/32$ .XX $\pm .12$ $\pm 1^\circ$ .XXX $\pm .060$	CONTRACT NO.		CONCORDE BATTERY CORPORATION 2009 SAN BERNARDINO RD, W. COVINA, CA 91790					
	APPROVALS		DATE		TITLE			
	DRAWN	ELH	3/01/00		BATTERY, 12 VOLT, AGM-1280T SERIES			
	CHECKED	S. VALDEZ	3/01/00		SIZE	CAGE CODE		
FINISH	NONE	APPROVED	JBT	3/04/00	DWG NO.	AGM-1280T	REV	F
SIMILAR TO	CALC WT	ISSUED	DH	11/17/21	SCALE	1:2.5	SHEET 1 OF 1	