

NOTES: UNLESS OTHERWISE SPECIFIED

1. SEE DRAWING NO. CB-00282 AND PROCEDURE P-1000 FOR ASSEMBLY AND TEST INSTRUCTION. PROCEDURES AND ASSEMBLY DRAWINGS ARE FOR INTERNAL USE ONLY.
2. ALL TESTING IS PERFORMED IAW BATTERY COUNCIL INTERNATIONAL STANDARDS.
3. DIMENSIONS ARE INCH [MILLIMETER].
4. TERMINAL HARDWARE KIT PROVIDED, PART NUMBER 6923.

REVISIONS			
REV	DESCRIPTION	DATE	APPROVED
A	METRICIZED INSERT	12/23/00	JBT
B	REVISED HEIGHT DIMS	8/2/13	JBT
C	REVISED CONTAINER & OAH DIMS	6/10/20	PH

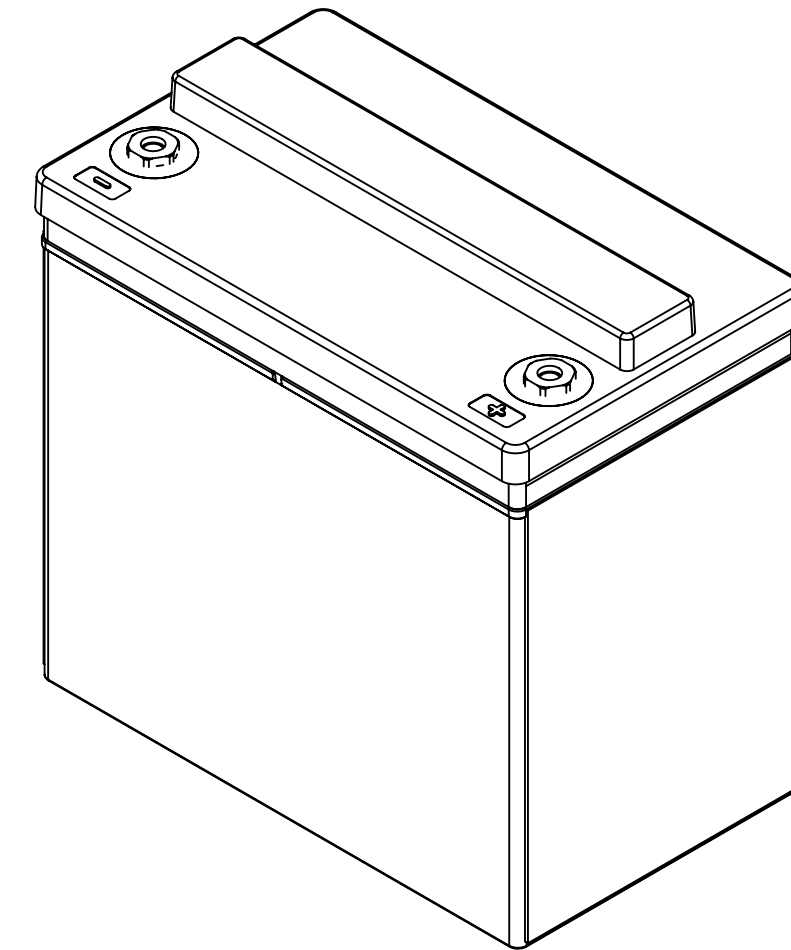
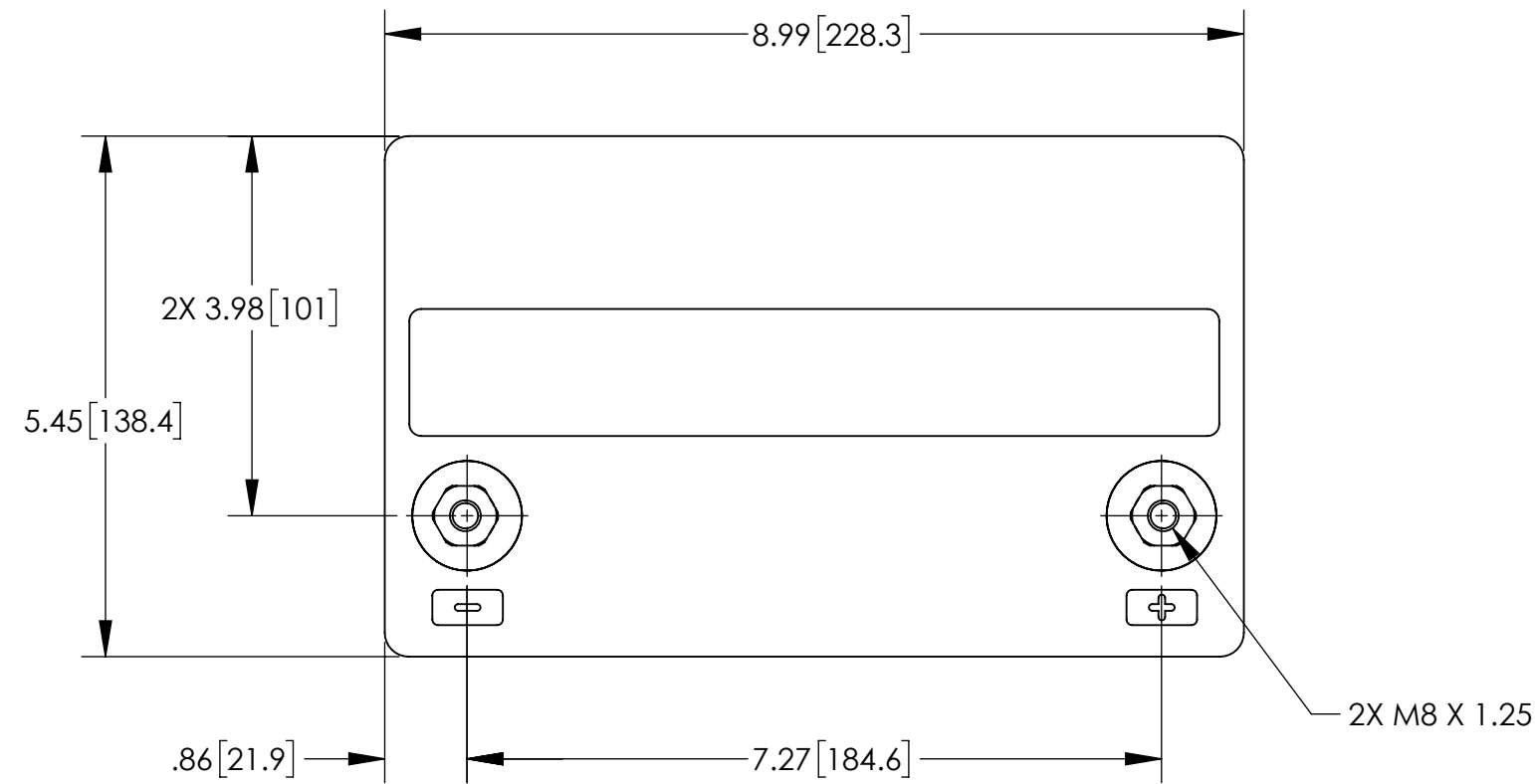

REFERENCE VIEW

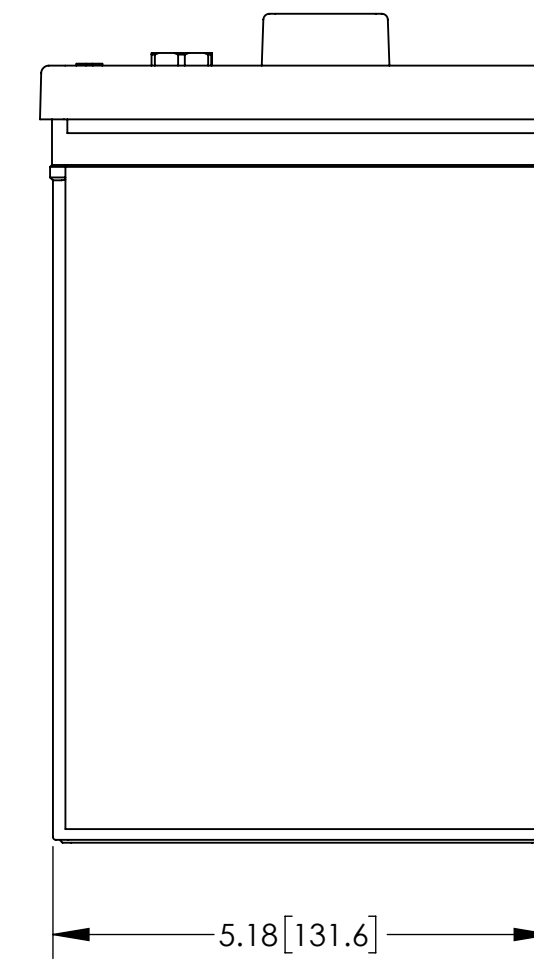
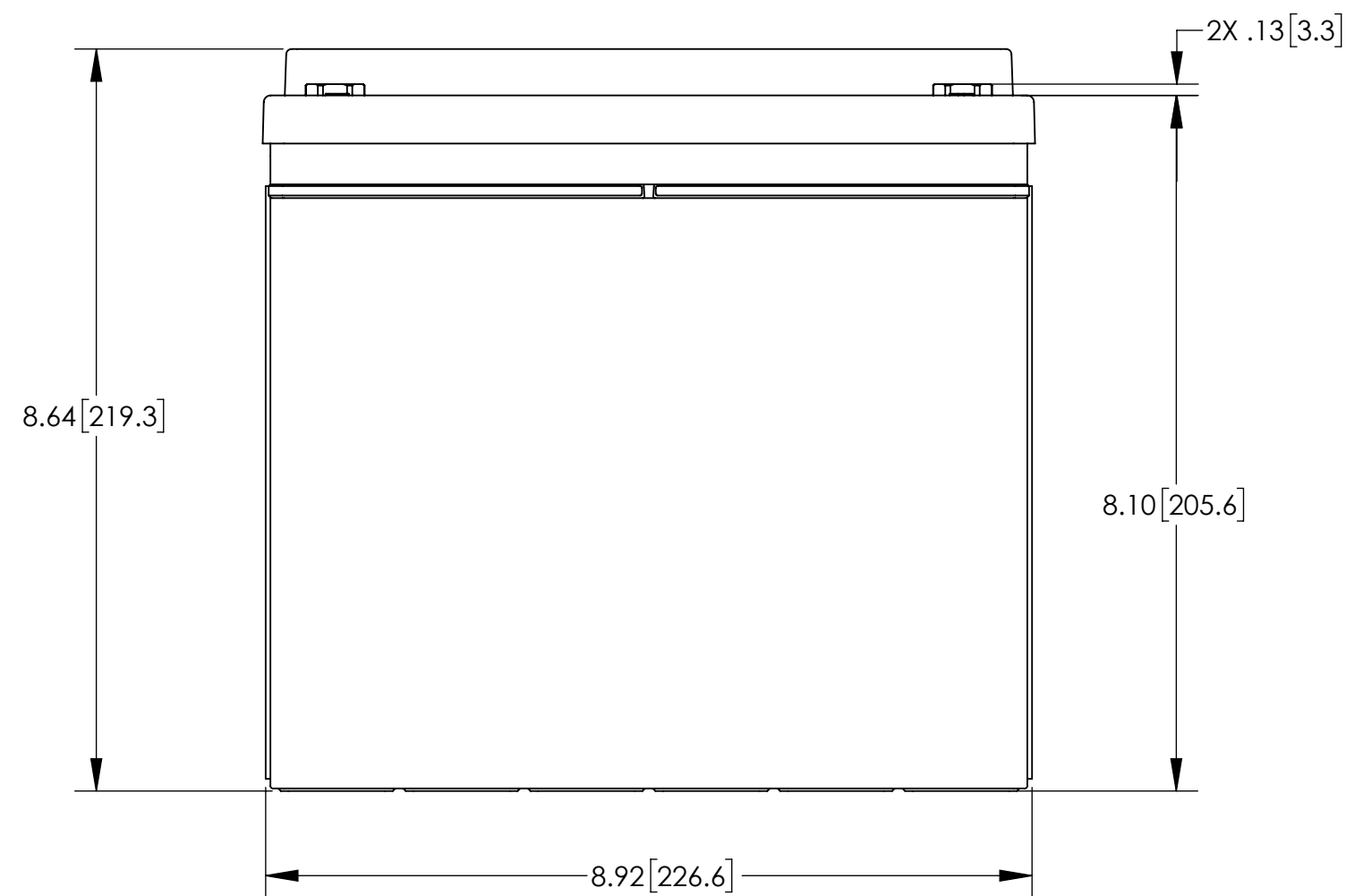

ENVELOPE DRAWING

CAPACITY RATINGS		
PART NUMBER	AGM-1248T	AGM-1255T
NOMINAL WEIGHT	35 LBS [15.9 KG]	39 LBS [17.7 KG]
AMPERE HOUR CAPACITY @20 HOUR 1.75 VOLTS/CELL @77° F (25° C)	48 AH	55 AH
MINUTES OF DISCHARGE @25 AMPS 1.75 VOLTS/CELL @77° F (25° C)	84 MIN	96 MIN

UNLESS OTHERWISE SPECIFIED DIMENSIONS ARE IN INCHES TOLERANCES ARE:			CONTRACT NO.		CONCORDE BATTERY CORPORATION 2009 SAN BERNARDINO RD, W. COVINA, CA 91790			
FRACTIONS	DECIMALS	ANGLES	APPROVALS	DATE	TITLE			
±1/32	.XX ± .12 .XXX ± .060	±1°	DRAWN ELH	3/16/00	BATTERY, 12 VOLT, AGM-1255T SERIES			
TREATMENT	NONE	CHECKED S. VALDEZ	3/16/00	SIZE	CAGE CODE	DWG NO.	REV	
FINISH	NONE	APPROVED DG	3/23/00	C	63017	AGM-1255T	C	
SIMILAR TO	CALC WT	ISSUED DH	6/11/20	SCALE	1:2	SHEET 1 OF 1		