

NOTES: UNLESS OTHERWISE SPECIFIED

1. SEE DRAWING NO. CB-00400 AND PROCEDURE P-1000 FOR ASSEMBLY AND TEST INSTRUCTIONS. PROCEDURES AND ASSEMBLY DRAWING ARE FOR INTERNAL USE ONLY.
2. ALL TESTING IS PERFORMED IAW BATTERY COUNCIL INTERNATIONAL STANDARDS.
3. DIMENSIONS ARE INCH [MILLIMETER].
4. TERMINAL HARDWARE KIT PROVIDED, PART NUMBER 6923.

REVISIONS			
REV	DESCRIPTION	DATE	APPROVED
A	REVISED WEIGHT, 90 LBS [40.8 KG] WAS 96 LBS [43.5 KG]	12/4/12	JBT
B	REDESIGNED COVER	12/20/17	PH
C	STANDARDIZED ENVELOPE, ADDED NOTE 4	7/21/20	PH

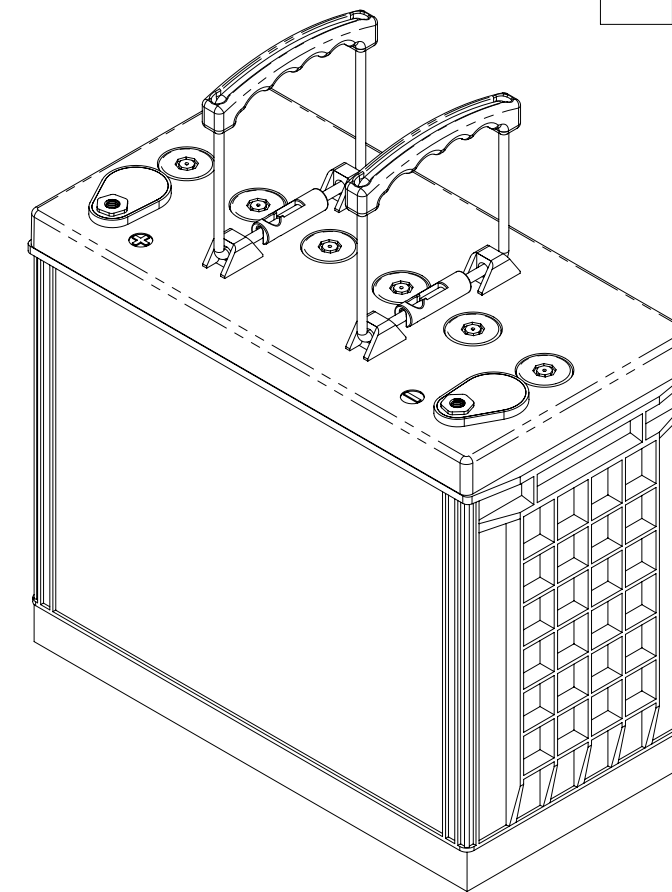
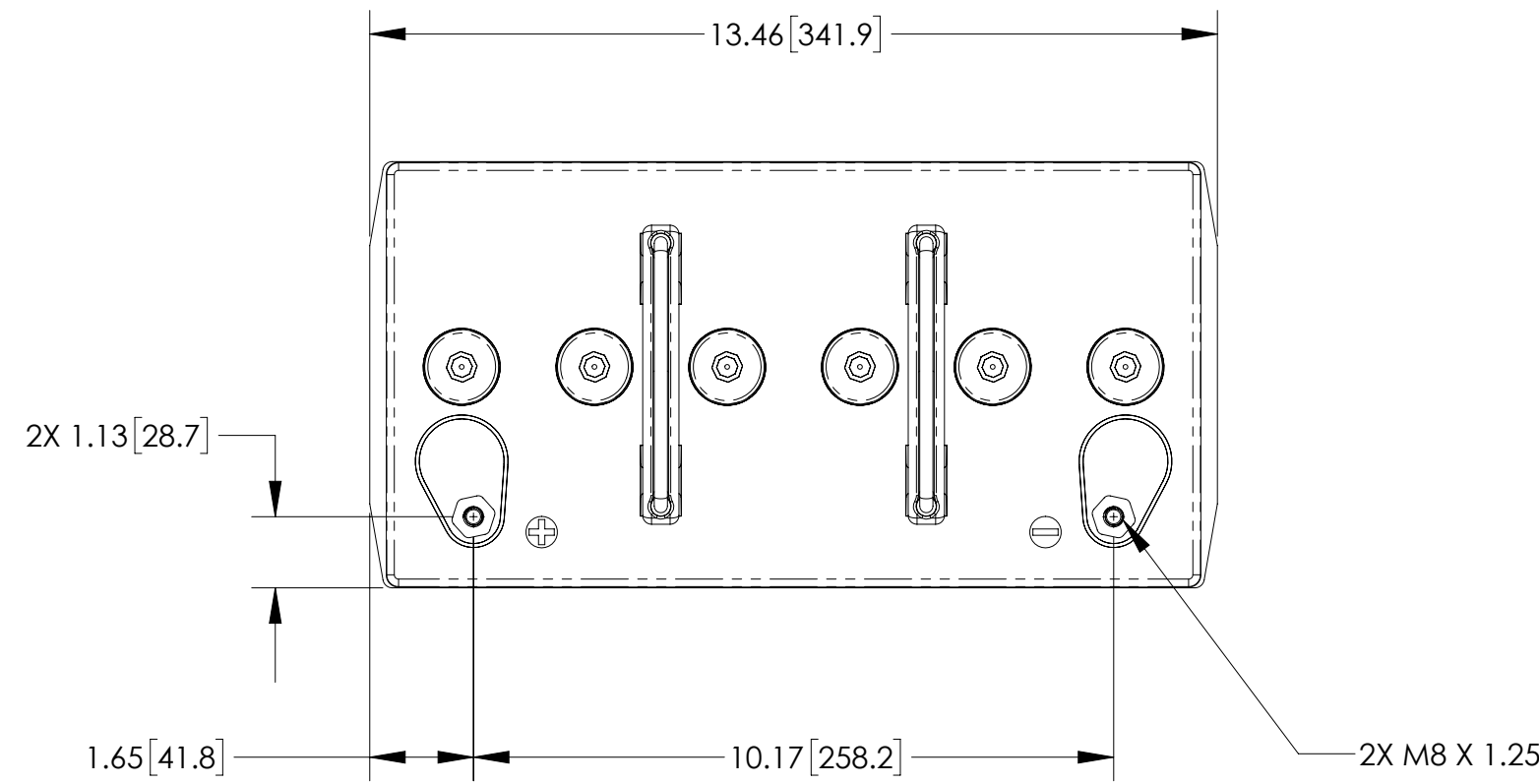

ISOMETRIC VIEW

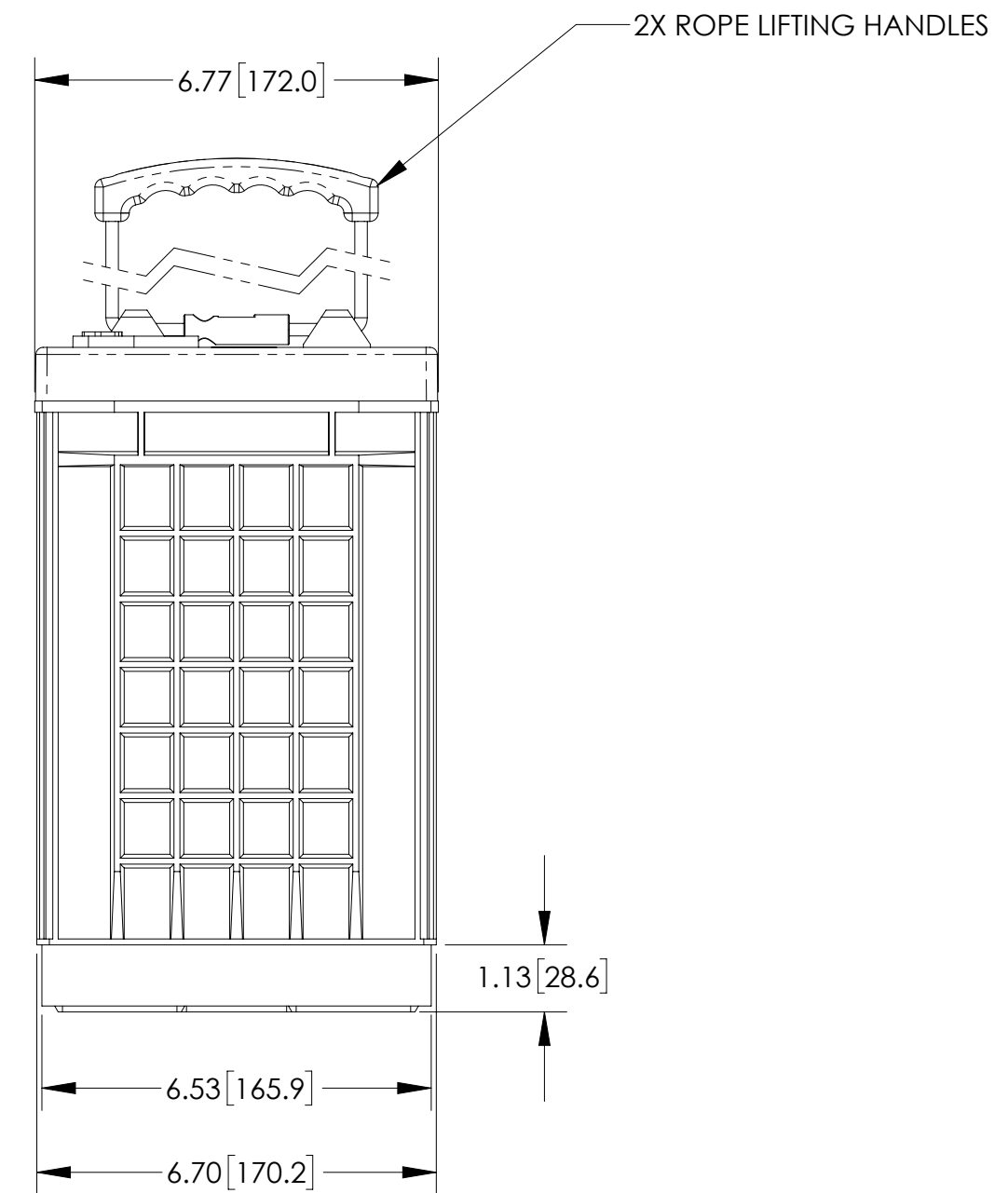
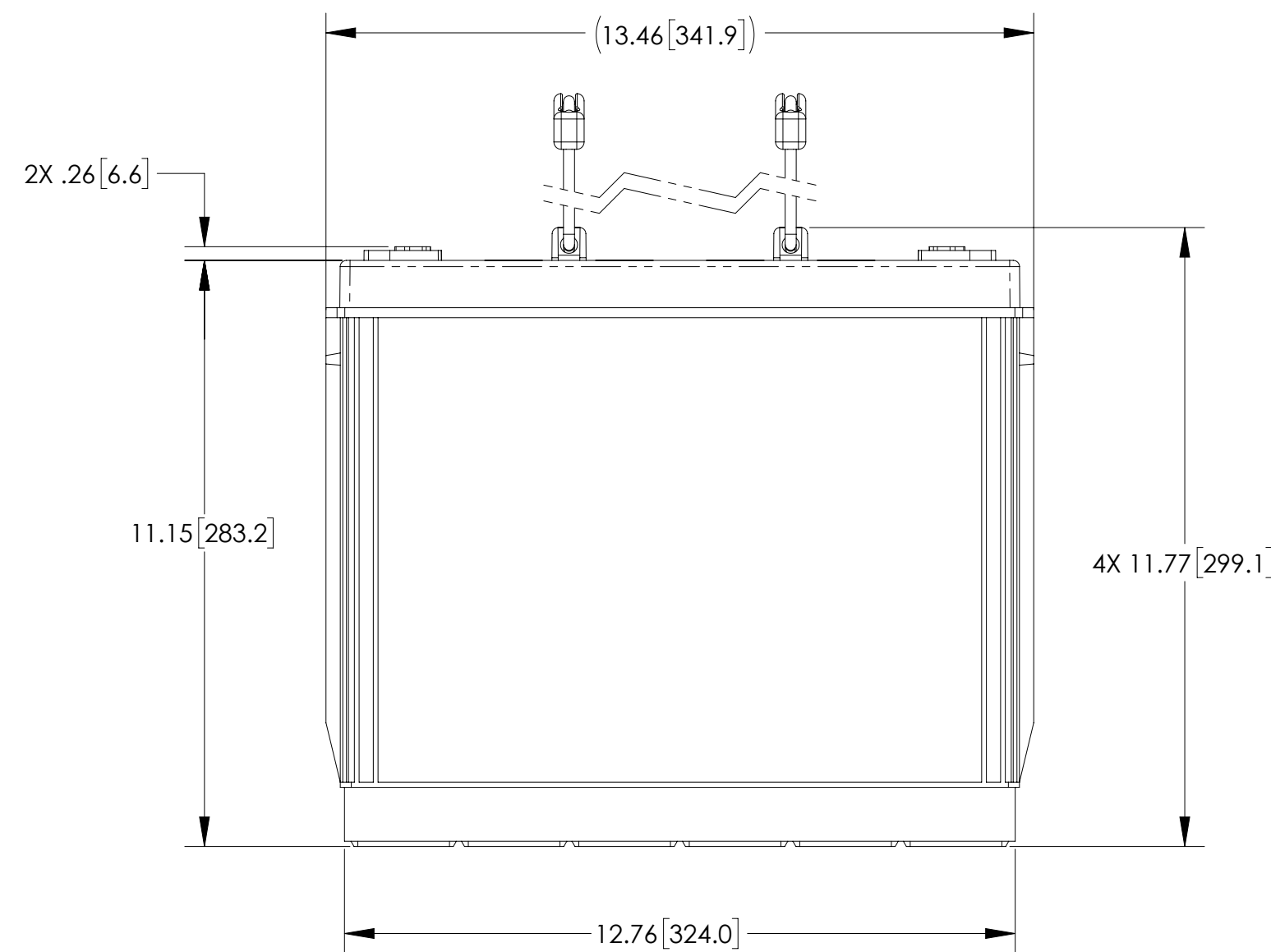

ENVELOPE DRAWING

CAPACITY RATINGS	
PART NUMBER	AGM-12148T
NOMINAL WEIGHT	90 LBS [40.8 KG]
AMPERE HOUR CAPACITY @ 20 HOUR 1.75 VOLTS/CELL @ 77°F (25°C)	150 AH
MINUTES OF DISCHARGE @ 25 AMPS 1.75 VOLTS/CELL @ 77°F (25°C)	315 MIN

UNLESS OTHERWISE SPECIFIED DIMENSIONS ARE IN INCHES TOLERANCES ARE:			CONTRACT NO.		CONCORDE BATTERY CORPORATION 2009 SAN BERNARDINO RD, W. COVINA, CA 91790			
FRACTIONS	DECIMALS	ANGLES	APPROVALS	DATE	TITLE			
±1/32	.XX ±.12 .XXX ±.060	±1°	DRAWN	6/30/09	BATTERY, 12 VOLT, AGM-12148T			
TREATMENT	NONE	CHECKED	AMIII	7/13/09	SIZE	CAGE CODE	DWG NO.	REV
FINISH	NONE	APPROVED	JBT	7/14/09	C	63017	AGM-12148T	C
SIMILAR TO	CALC WT	ISSUED	DH	7/23/20	SCALE	1:3	SHEET 1 OF 1	