

NOTES: UNLESS OTHERWISE SPECIFIED

1. SEE DRAWING NO. CB-00293 AND PROCEDURE P-1000 FOR ASSEMBLY AND TEST INSTRUCTION. PROCEDURES AND ASSEMBLY DRAWINGS ARE FOR INTERNAL USE ONLY.
2. ALL TESTING ARE IAW BATTERY COUNCIL INTERNATIONAL STANDARDS.
3. ALL DIMENSIONS ARE IN INCHES [MM].

REVISIONS			
REV	DESCRIPTION	DATE	APPROVED
A	REVISED TERMINAL WAS: M8...	12/23/00	JBT

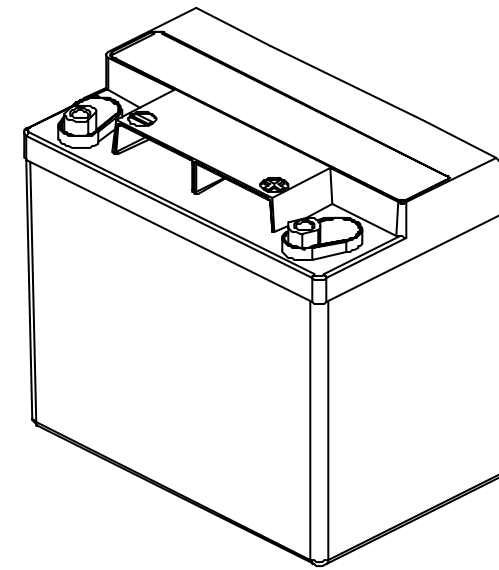
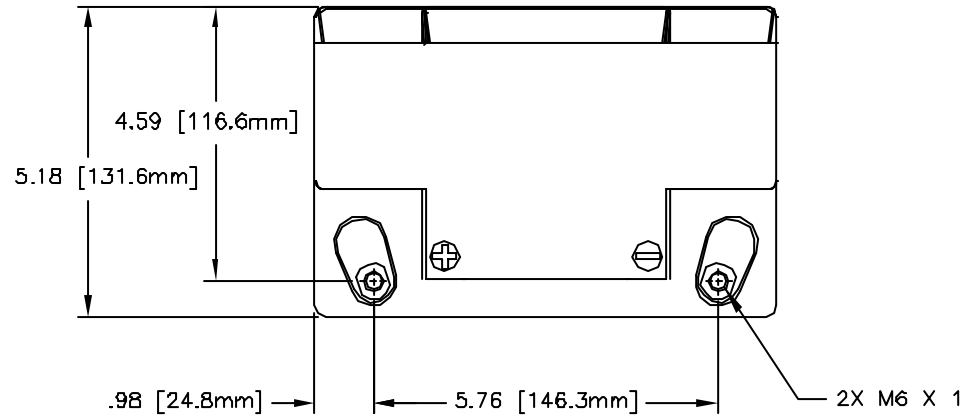

REFERANCE VIEW

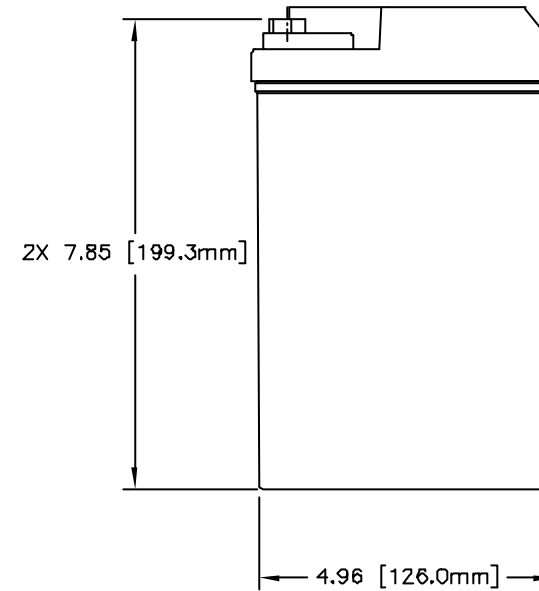
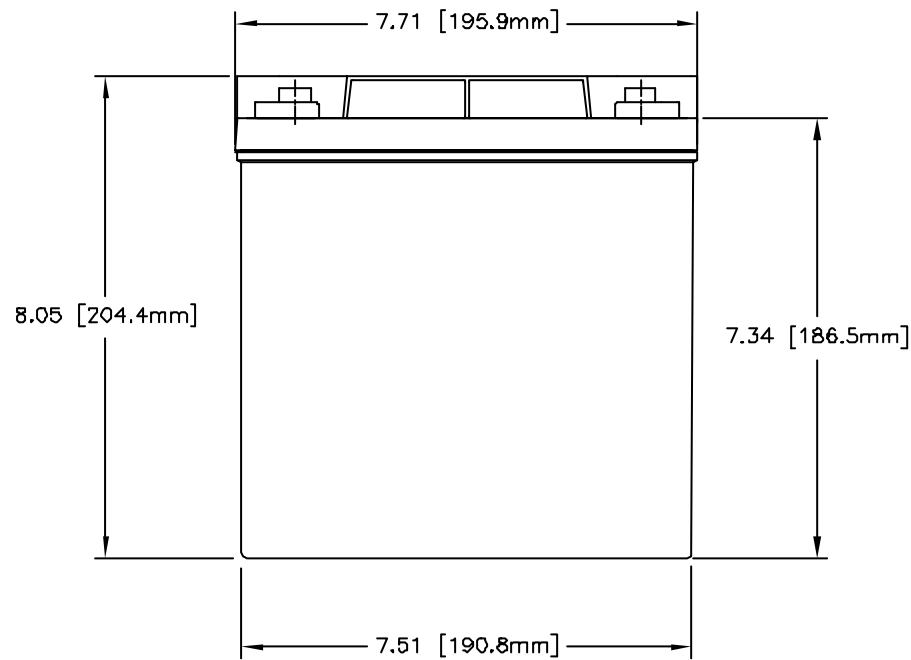

ENVELOPE DRAWING

CAPACITY RATINGS	
PART NUMBER	AGM-1240T
NOMINAL WEIGHT	29 LBS[13.2 KG]
AMPERE HOUR CAPACITY @ 20 HOUR 1.75 VOLTS/CELL @ 77°F (25° C)	40 AH
MINUTES OF DISCHARGE @ 25 AMPS 1.75 VOLTS/CELL @ 77°F (25° C)	61 MIN

QTY REQD	DATE CODE	PART OR IDENTIFYING NO.	NOMENCLATURE OR DESCRIPTION	MATERIAL SPECIFICATION	ITEM NO.
PARTS LIST					
UNLESS OTHERWISE SPECIFIED DIMENSIONS ARE IN INCHES TOLERANCES ARE:			CONCORDE BATTERY CORPORATION 2009 SAN BERNARDINO RD, W. COVINA, CA 91790		
FRACTIONS	DECIMALS	ANGLES	APPROVALS	DATE	TITLE
	XX ± .05		DRAWN	ELH	3/21/00
	XXX ± .050		CHECKED	S. VALDEZ	3/21/00
TREATMENT	NONE		APPROVED	DG	3/22/00
FINISH	NONE		ISSUED	AT	01/11/01
SIMILAR TO N/A	ACT WT N/A	CALC WT N/A	SCALE	NONE	
			SIZE	CAGE CODE	DWG NO.
			C	63017	AGM-1240T
			REV	A	
			SHEET	1	OF 1